

# Systems in Mechanical Engineering 202041

Mr. K. B. Bansode

# Course Objectives:

---

1. To identify the sources of energy and their conversions
2. To explain the basic concept of engineering thermodynamics and its application
3. To understanding the specifications of vehicles
4. To get acquainted with vehicle systems
5. To introduce manufacturing processes applying proper method to produce components
6. To be able to select and compare domestic appliances



# Course Outcomes

---

On completion of the course, learner will be able to

CO1: Describe and compare the conversion of energy from renewable and non-renewable energy sources

CO2: Explain basic laws of thermodynamics, heat transfer and their applications

CO3: List down the types of road vehicles and their specifications

CO4: Illustrate various basic parts and transmission system of a road vehicle

CO5: Discuss several manufacturing processes and identify the suitable process

CO6: Explain various types of mechanism and its application

# Unit I Introduction of energy sources & its conversion

---

- **Energy sources:** Thermal energy, Hydropower energy, Nuclear energy, Solar energy, Geothermal energy, Wind energy, Hydrogen energy, Biomass energy and Tidal energy. Grades of Energy. (*Numerical on efficiency calculation of thermal power plant*)
- **Energy conversion devices:** Introduction of pump, compressor, turbines, wind mills etc
- (*Simple numerical on power and efficiency calculations*)



# Thermal energy

<https://www.youtube.com/watch?v=IdPTuwKEfmA>

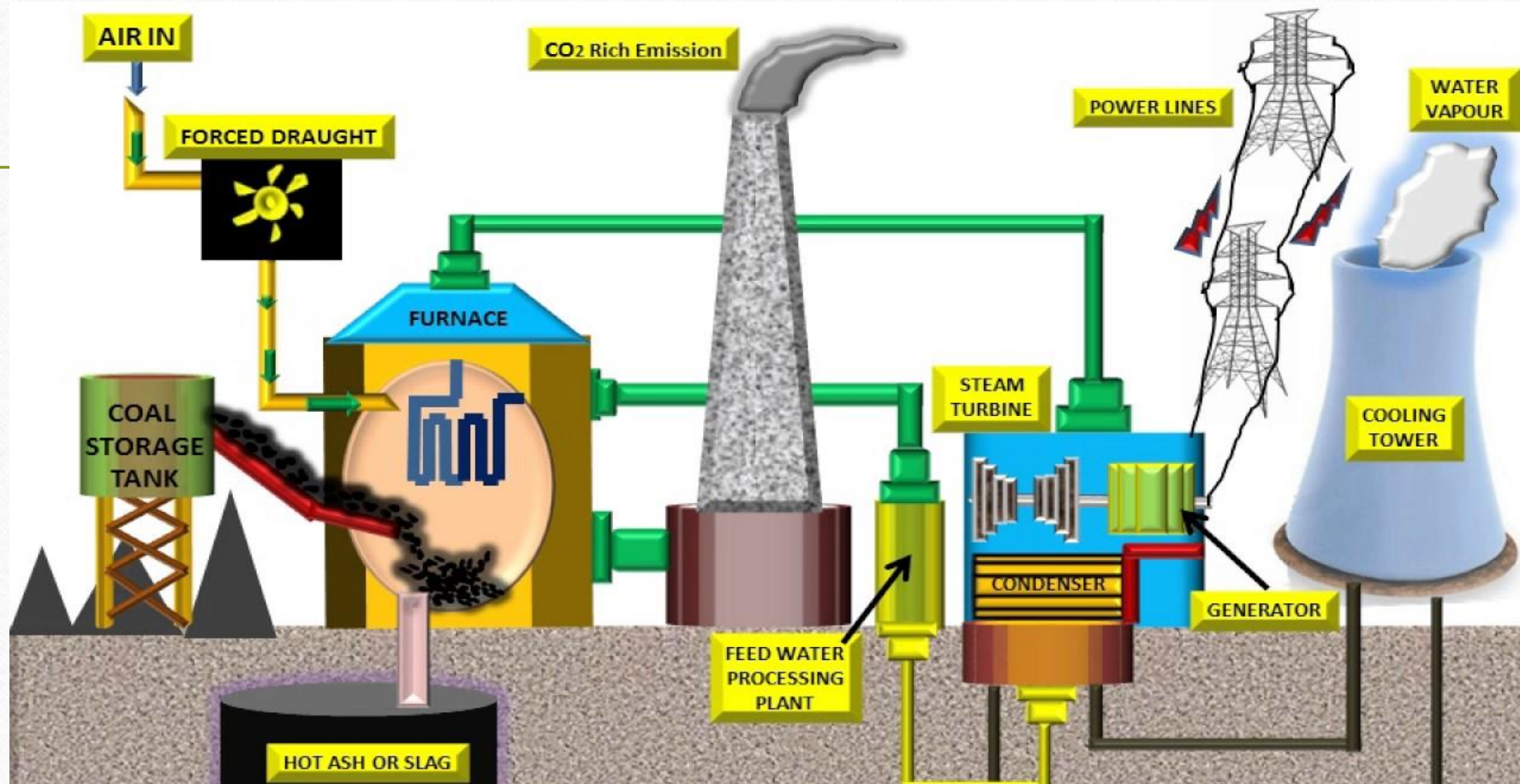

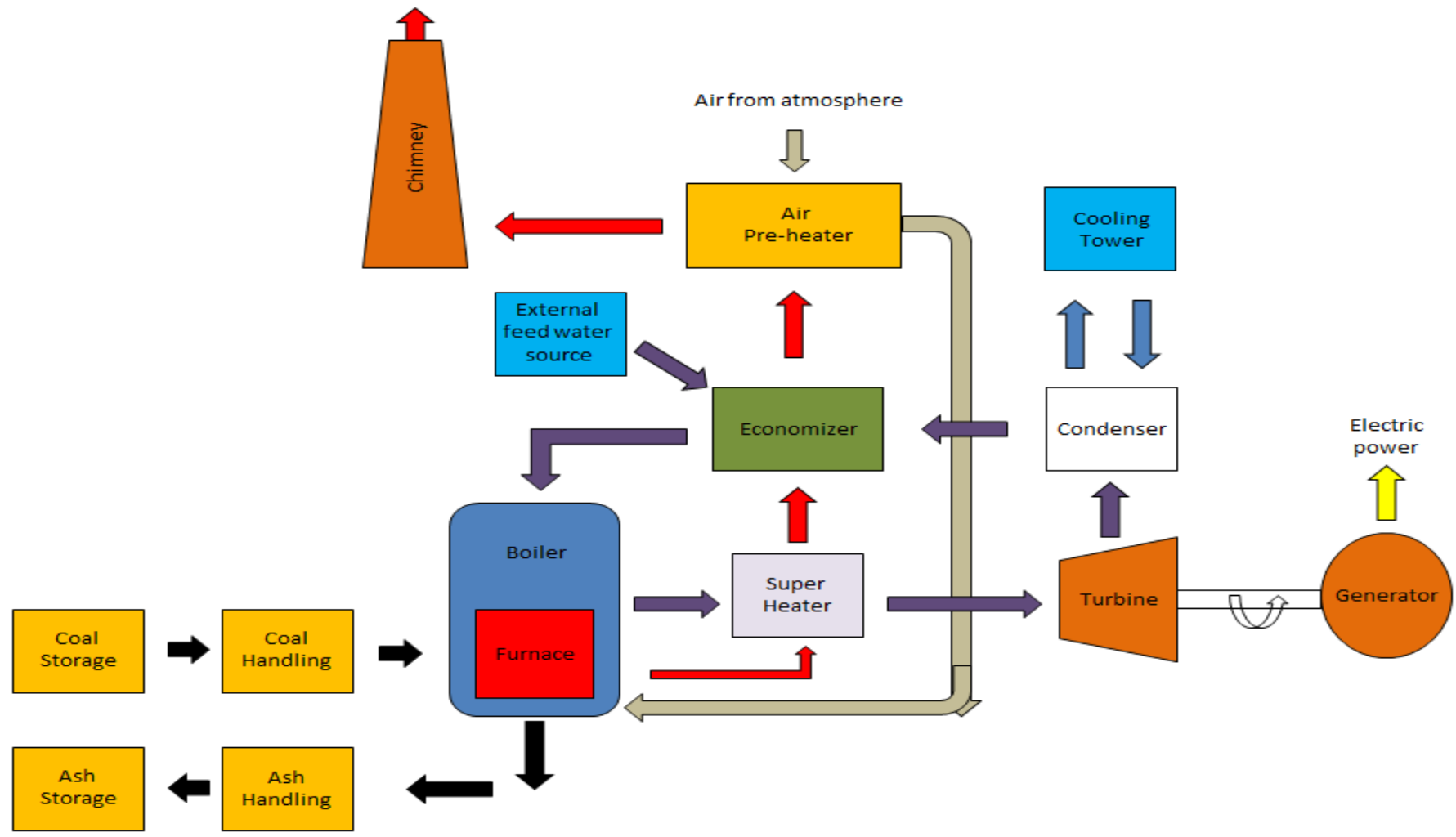



Electricity is generated by combustion of coal in a furnace. This heat is utilised to produce steam at high temperature and pressure. Steam is then used to run a turbine which is linked with the generator producing electricity.

Coal-fired thermal power plants are operated on the above principle by mechanical rotation of the steam turbine. In India, thermal power contributes about 65000 MW of electricity, that is, 70% of the total power supply. Some of the major thermal power stations of National Thermal Power Corporation (NTPC) of India are at Singrauli and Rihand in Up Farakka in West Bengal and Talchar in Orissa. They are the major source of thermal pollutants, flyash and decreased content of dissolved oxygen.

# HYDRO-ELECTRIC POWER PLANT:

<https://www.youtube.com/watch?v=Uhjhufhg3Xk>

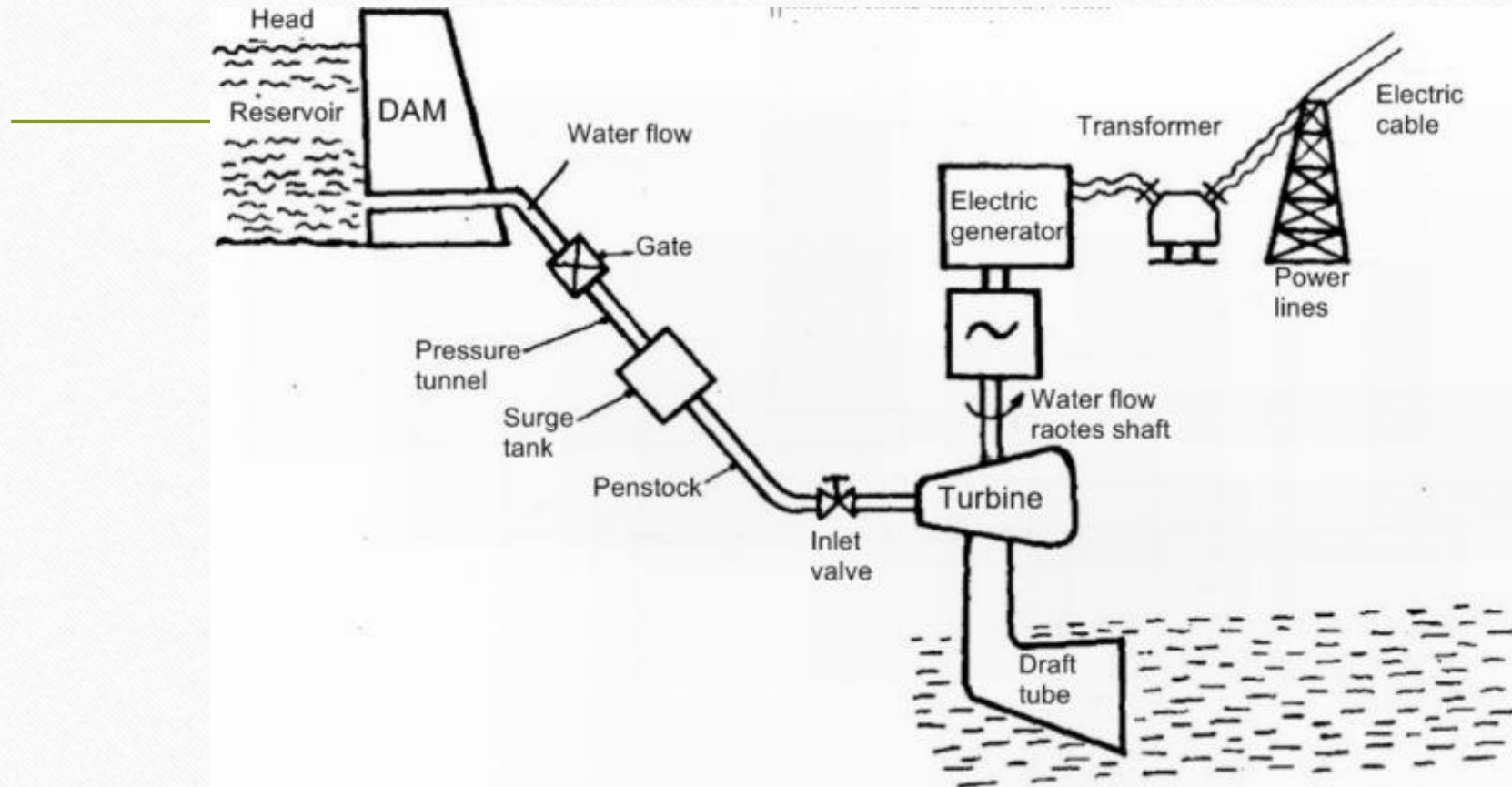



The main component of hydroelectric power plant and their functions are as follows.

1. **Reservoir:** Reservoir is provided to store water during rainy season and supply the same in dry season. The water from reservoir is used to run the hydraulic turbine. It determines the power generating capacity of the power plants.
2. **Dam:** A dam is structure of considerable height built across the river. Its function is to provide working head of water for power plant and to increase the storage capacity of reservoir.
3. **Trash rack:** these are made up of steel bars. Trash rack is provided to prevent entry of debris into the intakes from the dam or from the fore bays. Any debris into the intake water pipe may damage the turbine runner or choke the nozzles of an impulse turbine.
4. **Gate:** The gate is provided for controlling the flow of water from reservoir to hydraulic turbine through penstock closed when maintenance of system is required.
5. **Fore bays:** It is small water reservoir at the end of water passage from the reservoir and before the water is fed to the turbine to the penstock as shown in the diagram.
6. **Surge tank** In case the load on turbine suddenly decreases the gates admitting water to the turbine are suddenly closed due to governor action.

As a result it reduces the water flow with sudden increasing pressure in the penstock. This sudden rise of pressure in penstock is called water hammer.

7. **Water way and penstock:** Water way is used to carry water from dam to the power house. It includes canal and penstock (closed pipe) or tunnel. The penstocks are made up of reinforced concrete which is designed to withstand high pressure. Penstocks are supported by anchors sharp bends in the penstock are avoided in order to reduce the hydraulic losses.
8. **Spill way:** spillway is providing to discharge the flood water and to keep the level of water below the designed maximum level in the reservoir. The spillway saves the dam from damage during floods.
9. **Powerhouse:** Powerhouse consists of hydraulic and electric equipments where the water energy is converted into electrical energy. Usually the power houses are located underground whenever possible. E.g. As in case of Koyana power house in Maharashtra state.
10. **Hydraulic turbines:** these are used to convert the kinetic energy of water into mechanical energy.
11. **Draft tube:** a draft tube is passage which connects the exit from the turbine runner down to tail race water level. It supplements the action of runner of the reaction turbine by utilizing the remainder Kinetic energy of water at discharge end of runner. Another purpose of the draft tube is to permit the setting of runner to the reaction turbine wheel at a level above that of water in the tail race under high water and flood conditions of the river.
12. **Tail race:** A tail race is a water way to lead the water discharge from the turbine to the river



### Advantages of Hydroelectricity:

1. Hydroelectricity is basically non-polluting renewable clean source of energy.
2. There is no emission of green-house gases.
3. No consumption of fuel
4. No need of high technology.

### **Disadvantages:**

1. Dams are extremely expensive to build and must be built to a very high standard.
2. The high cost of dam construction means that they must operate for decades to become profitable.
3. The flooding of large areas and land means that the environment is destroyed.
4. The building of large dams can cause serious geological damage.
5. Building a large dam alters the natural water table level.
6. Dams built blocking the progress of river in one country usually means that the water supply from the same river in the following country is out of their control.

# Nuclear energy

<https://www.youtube.com/watch?v=UwexvaCMWA>

The nuclear power generating stations are similar to the thermal station in more than one ways. Uranium and Thorium are the radioactive elements used as primary fuel. Also, for the process, the radioactive fuels are made to undergo fission reaction within the nuclear reactor and by this process large amount of energy is produced which is manifested in the form of heat. This heat is then transferred to the water present in heat exchanger tubes. As a result, the superheated steam at very high temperature is produced. The remaining process is same as the thermal power generating station.



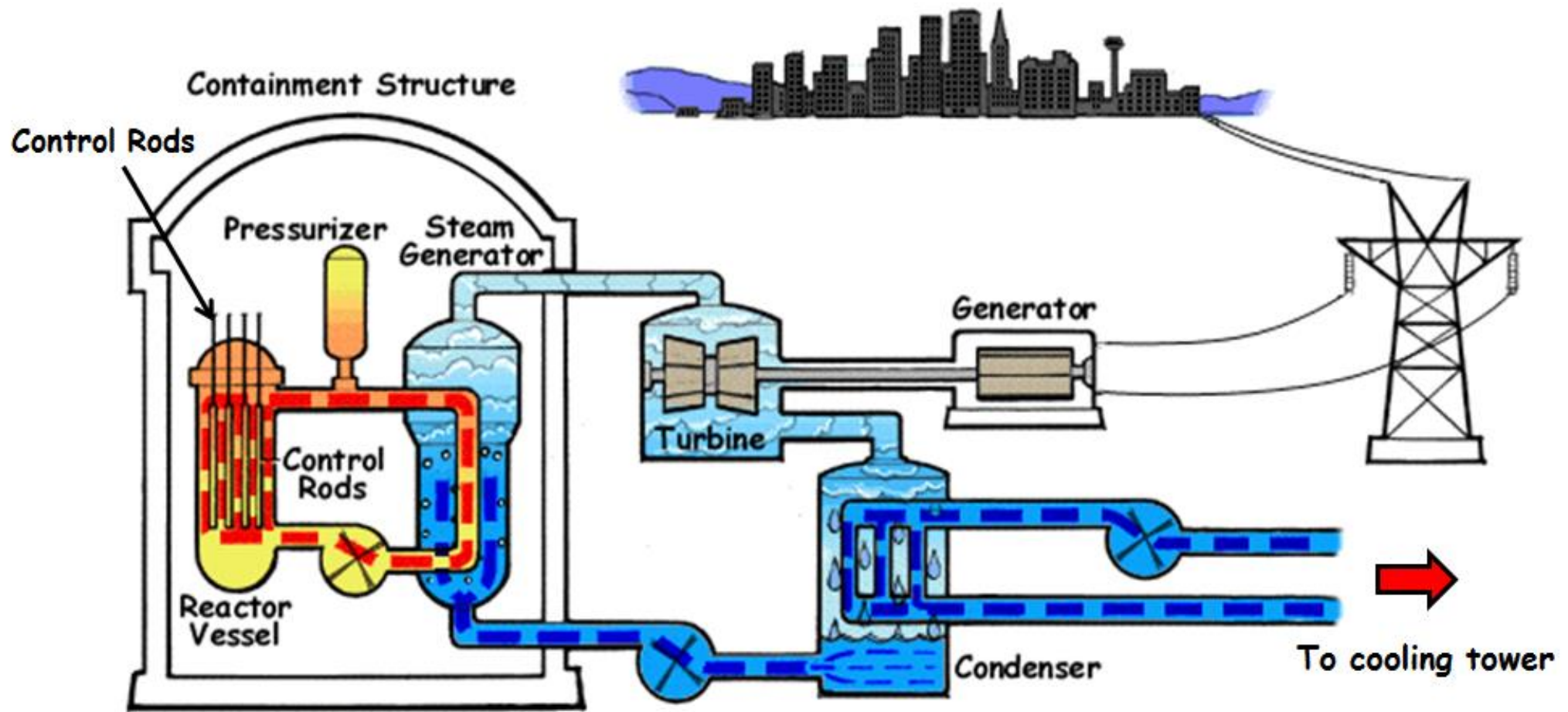

# Solar energy

<https://www.youtube.com/watch?v=X0OZ6tpZ3Mc>

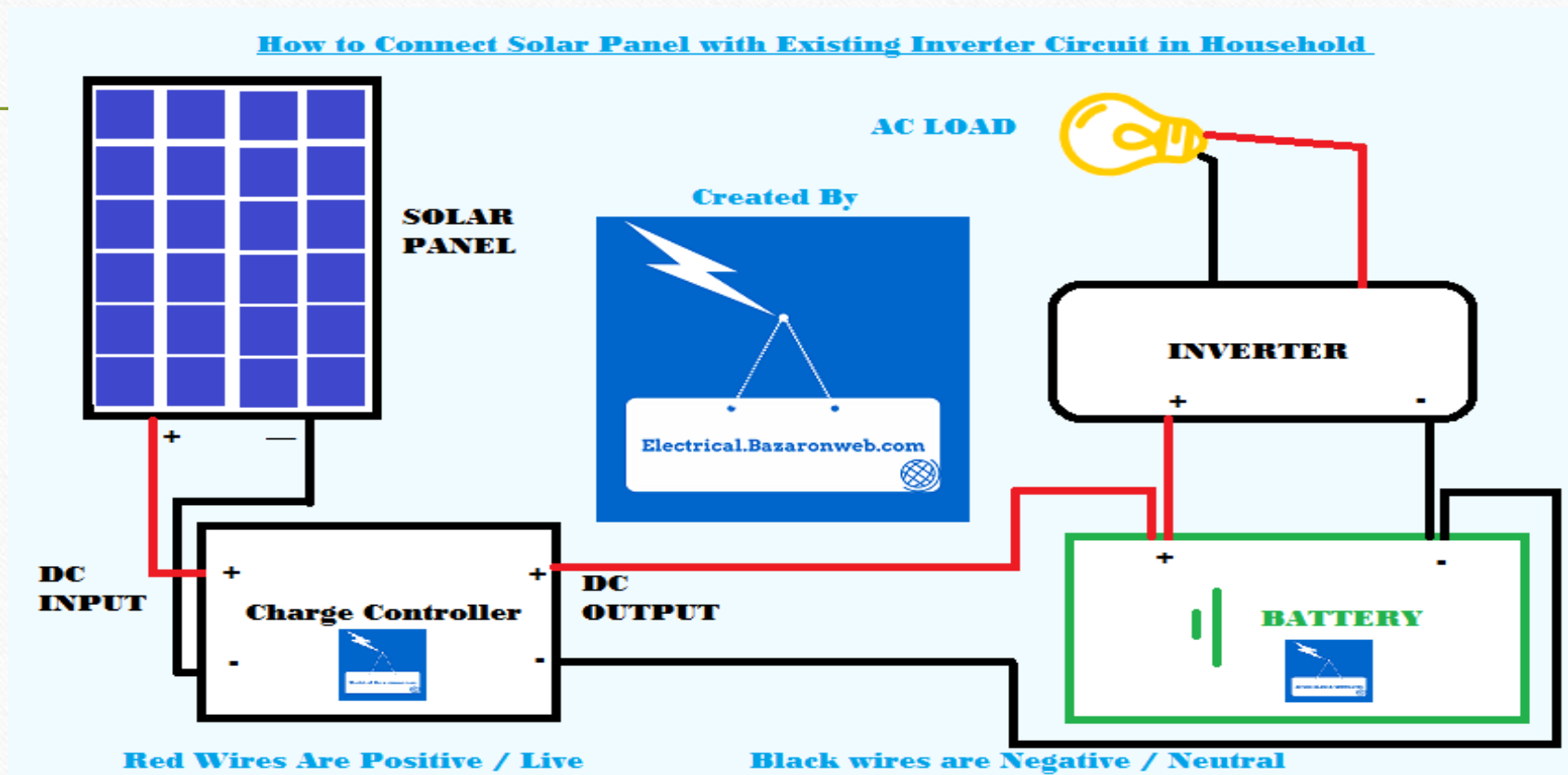



# Geothermal energy

<https://www.youtube.com/watch?v=mCRDf7QxjDk>

## How geothermal energy works

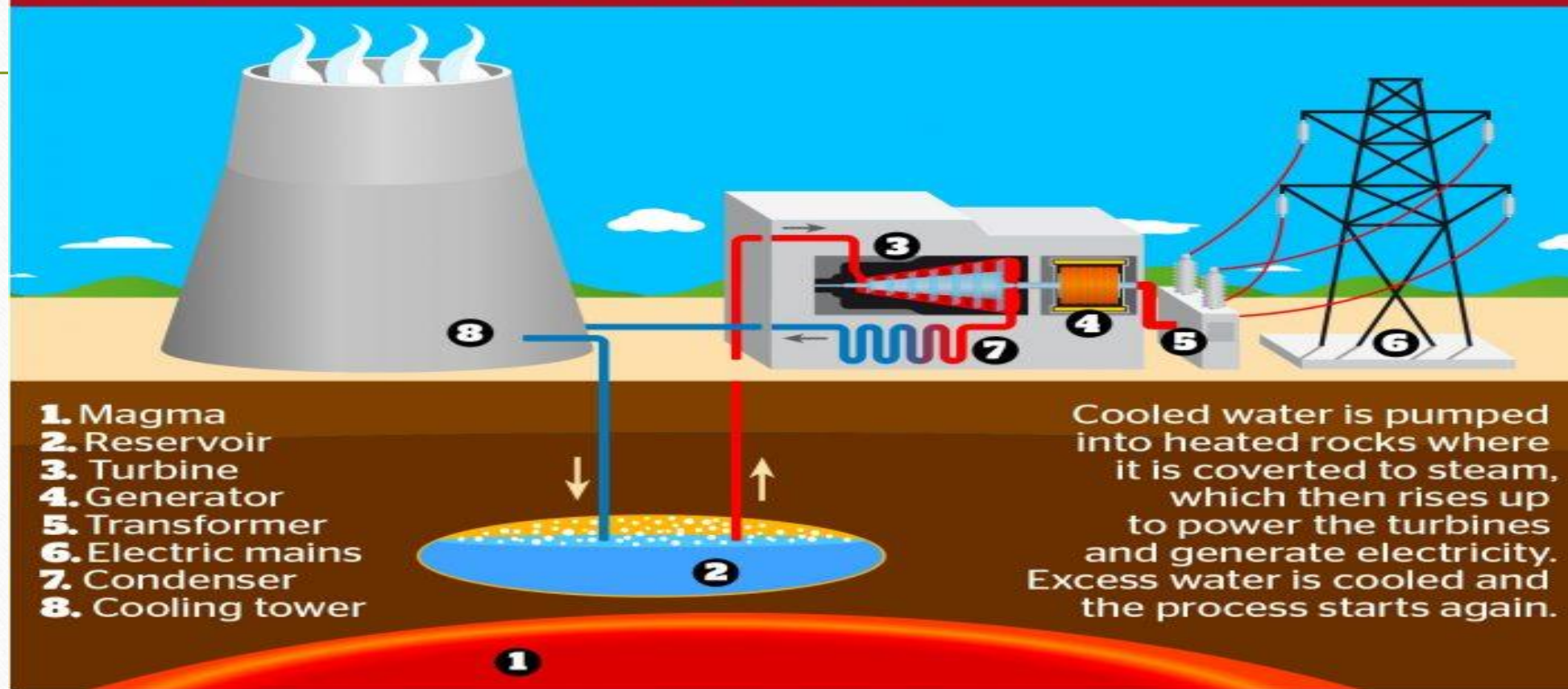

Geothermal energy is the heat that comes from the sub-surface of the earth. It is contained in the rocks and fluids beneath the earth's crust and can be found as far down to the earth's hot molten rock, magma.

To produce power from geothermal energy, wells are dug a mile deep into underground reservoirs to access the steam and hot water there, which can then be used to drive turbines connected to electricity generators. There are three types of geothermal power plants; dry steam, flash and binary.

Dry steam is the oldest form of geothermal technology and takes steam out of the ground and uses it to directly drive a turbine. Flash plants use high-pressure hot water into cool, low-pressure water whilst binary plants pass hot water through a secondary liquid with a lower boiling point, which turns to vapour to drive the turbine.



# Wind energy

[https://www.youtube.com/watch?v=qSWm\\_nprfqE](https://www.youtube.com/watch?v=qSWm_nprfqE)

<https://www.youtube.com/watch?v=EYYHfMCw-FI>



# Horizontal Axis Wind Turbine

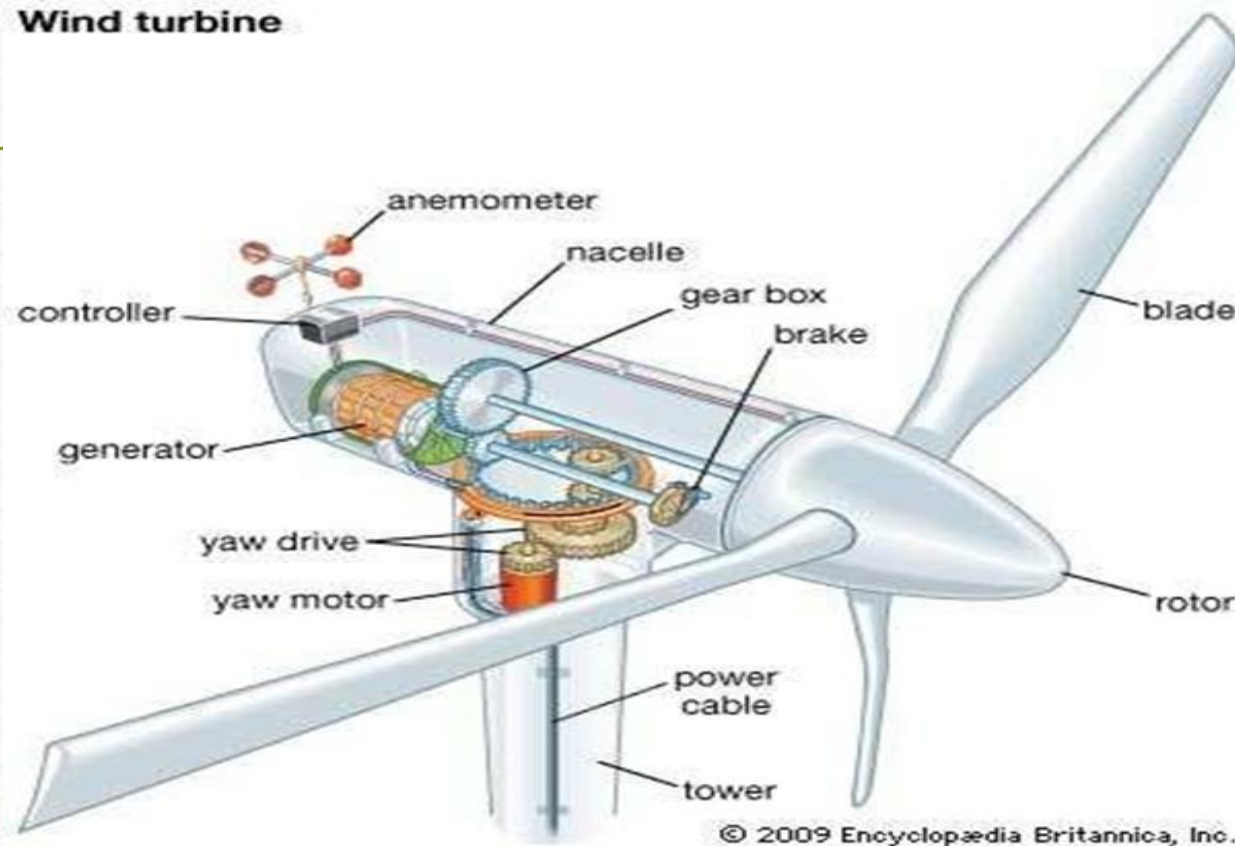



# Hydrogen energy

<https://www.youtube.com/watch?v=bFb5TKVPSiY>

[https://www.youtube.com/watch?v=imV\\_uflzxPY](https://www.youtube.com/watch?v=imV_uflzxPY)

<https://www.youtube.com/watch?v=9zgx-PIDEKA>

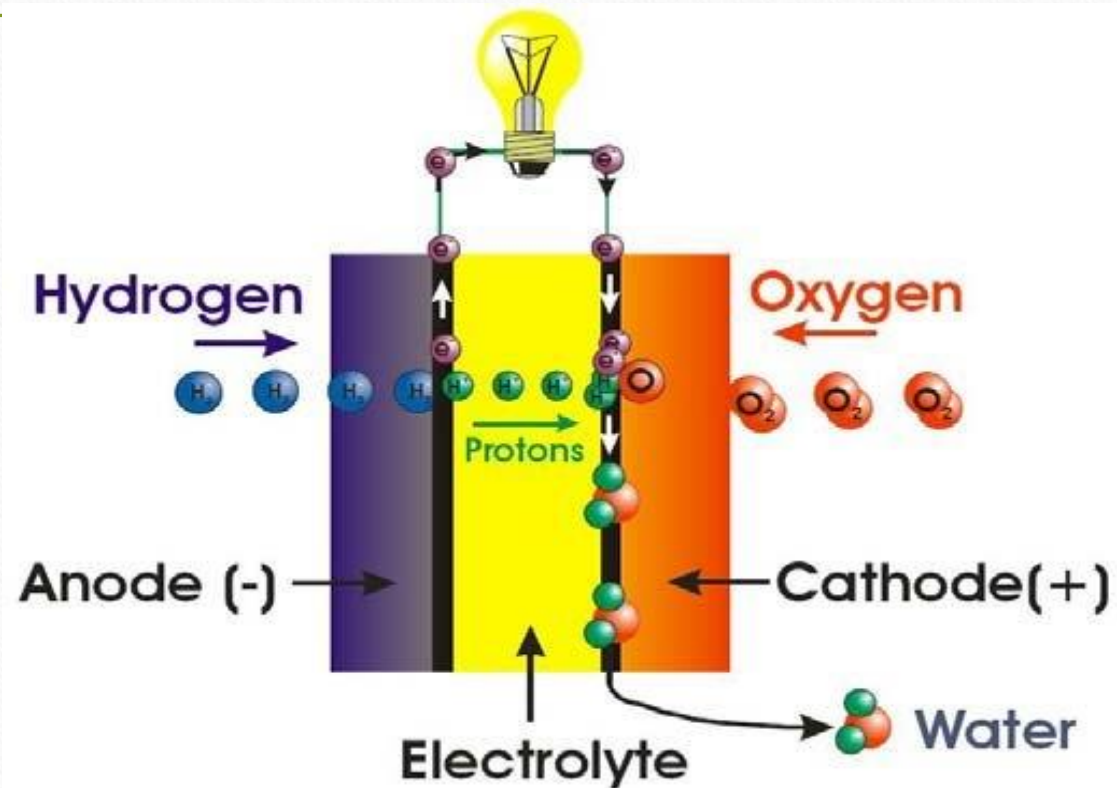

# Biomass energy

<https://www.youtube.com/watch?v=dQ-cIVJuDks>

<https://www.youtube.com/watch?v=PmBx5Zo8KZo>

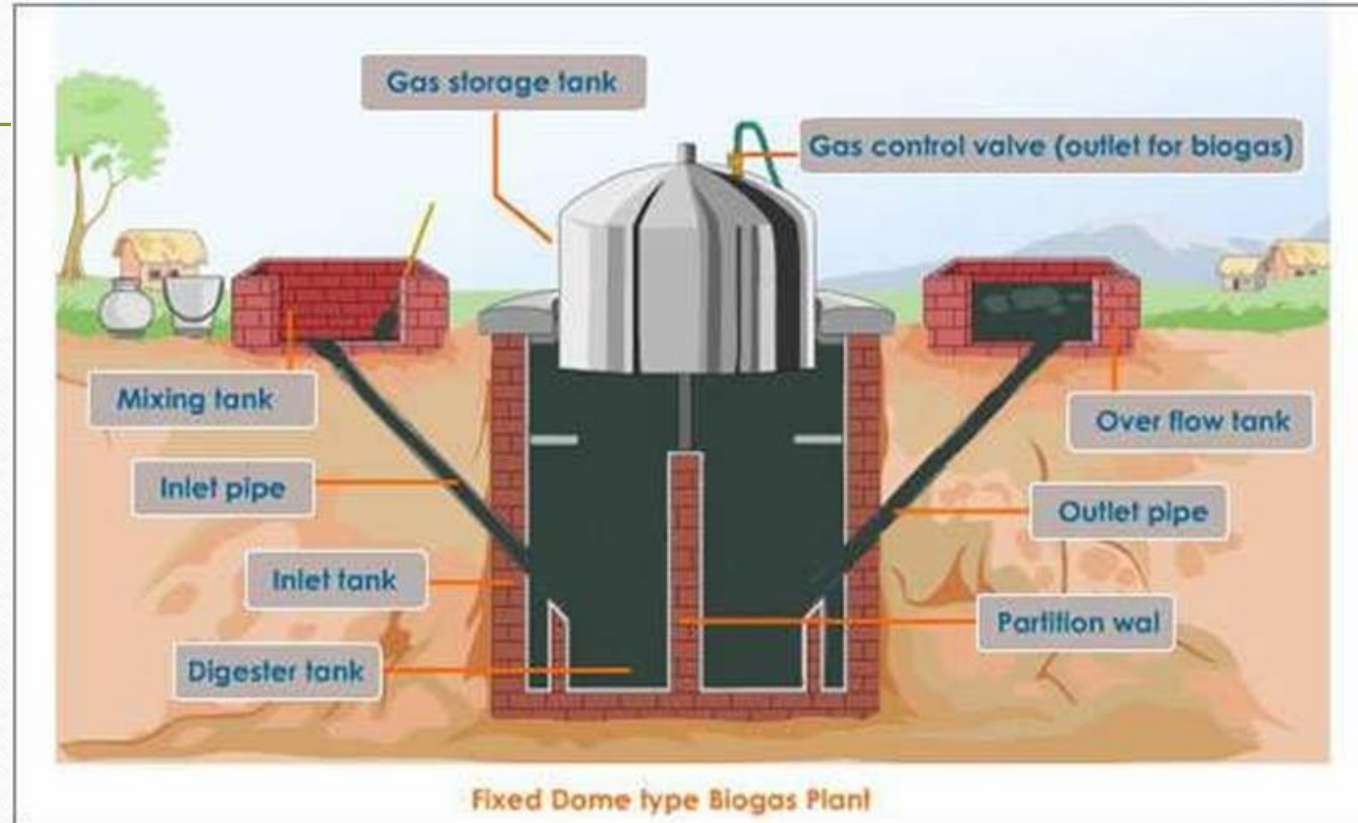



# Thermochemical Conversion of Biomass to Biofuels via Gasification

<https://www.youtube.com/watch?v=kI7s6IRpOHA>

<https://www.youtube.com/watch?v=OKpzClZWt4g&t=4s>

<https://www.youtube.com/watch?v=3K1zWAYDvMA>

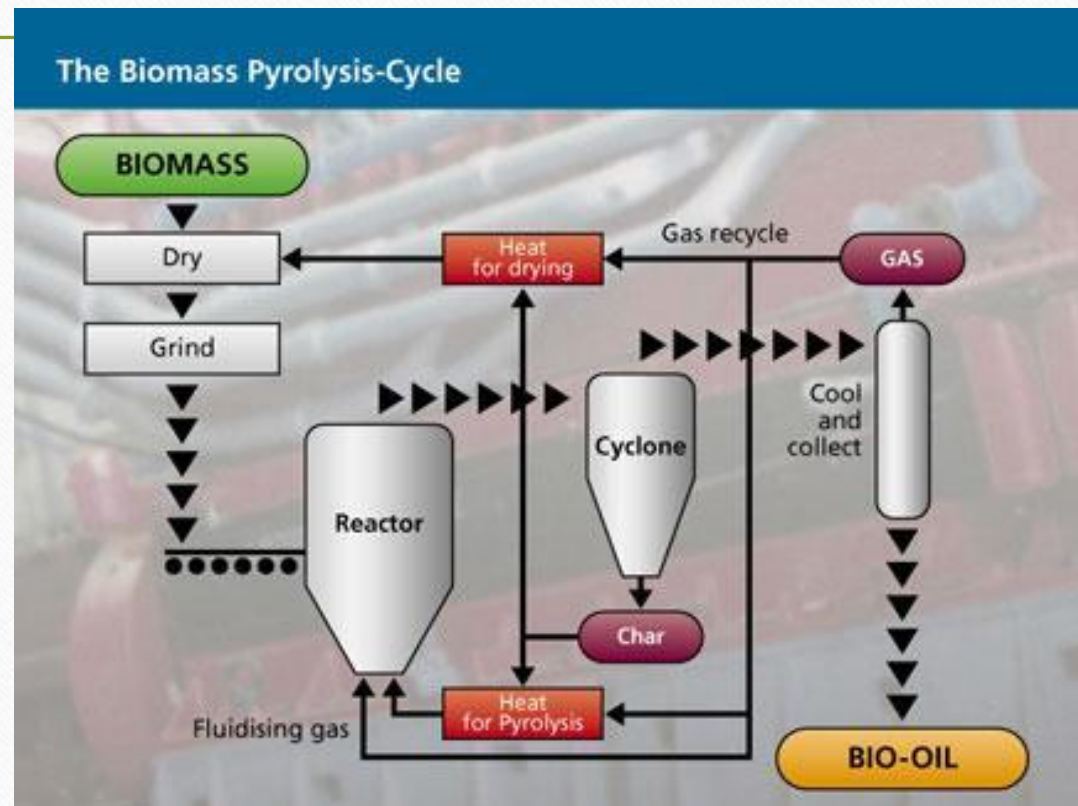



# Tidal energy

<https://www.youtube.com/watch?v=m7ImT4CdcPo>

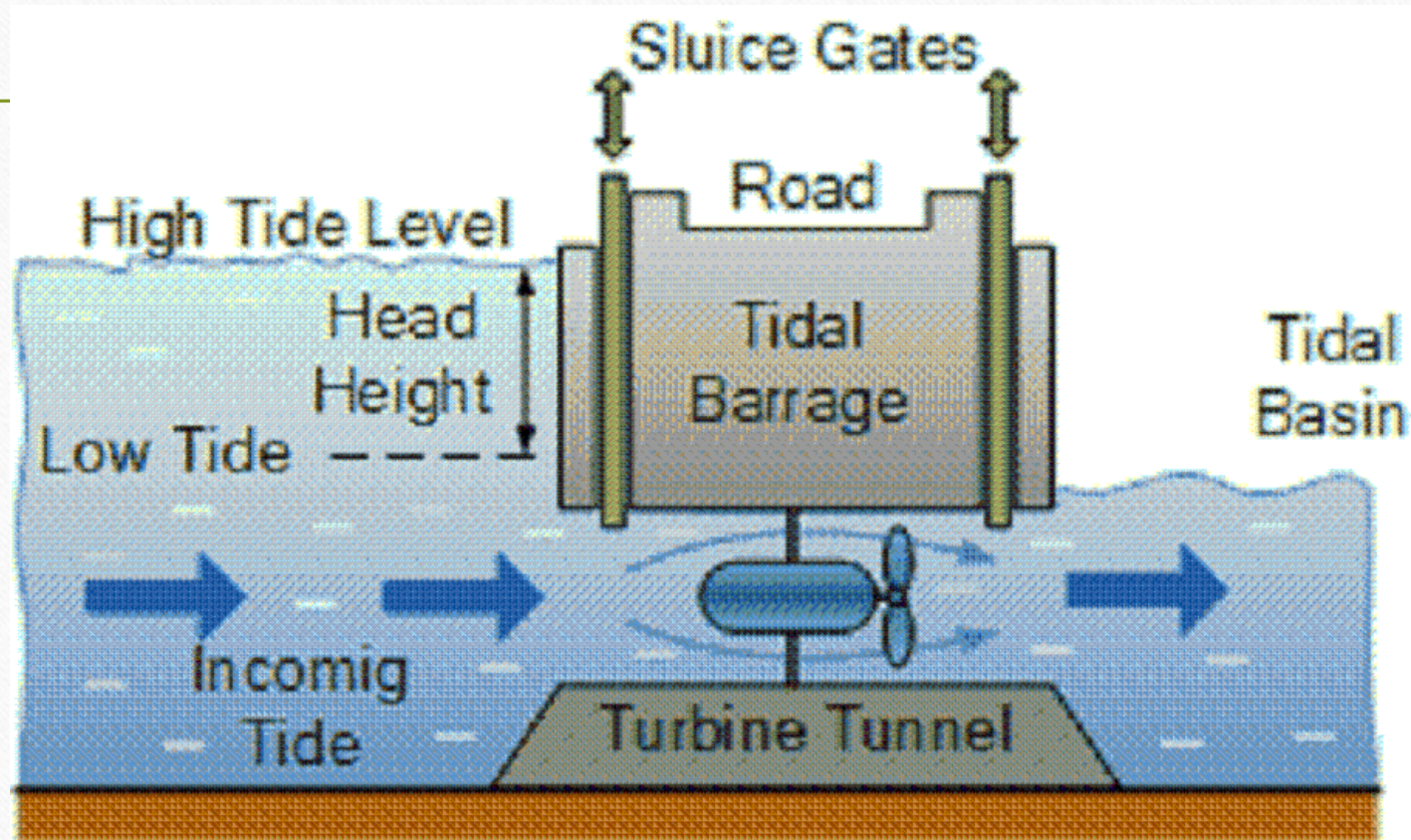



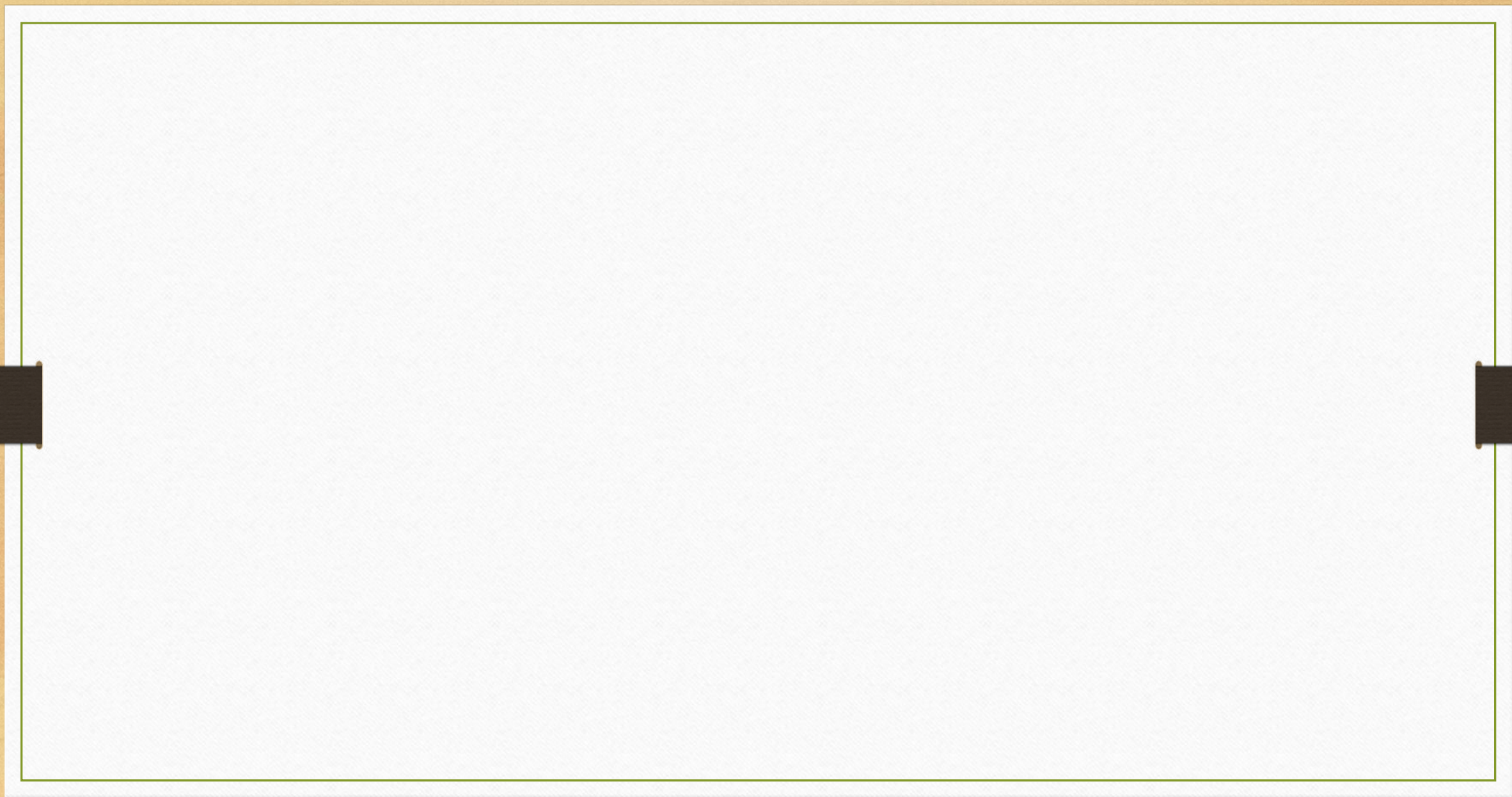

# PUMPS

<https://www.youtube.com/watch?v=BaEHVpKc-1Q>

<https://www.youtube.com/watch?v=SEkquRlP5Nw>

---

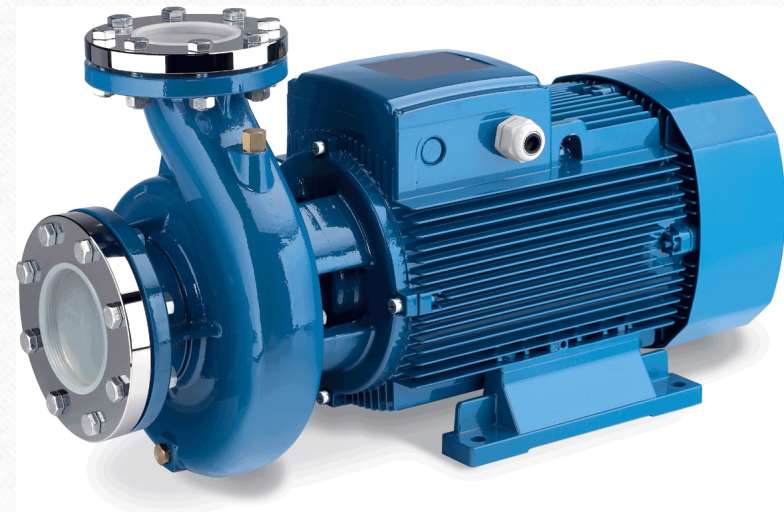
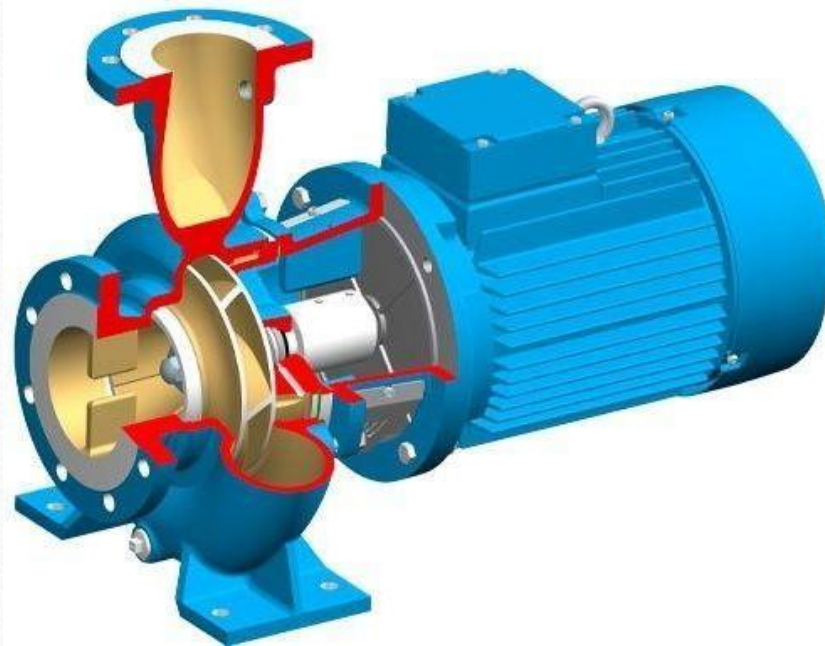



RECIPROCATING  
PUMP

CENTRIFUGAL PUMP

**PUPM**

- Pumps are hydraulic machines which convert the mechanical energy into hydraulic energy
- Pump is generally used for raising liquid from low level to high level



# CENTRIFUGAL PUMP

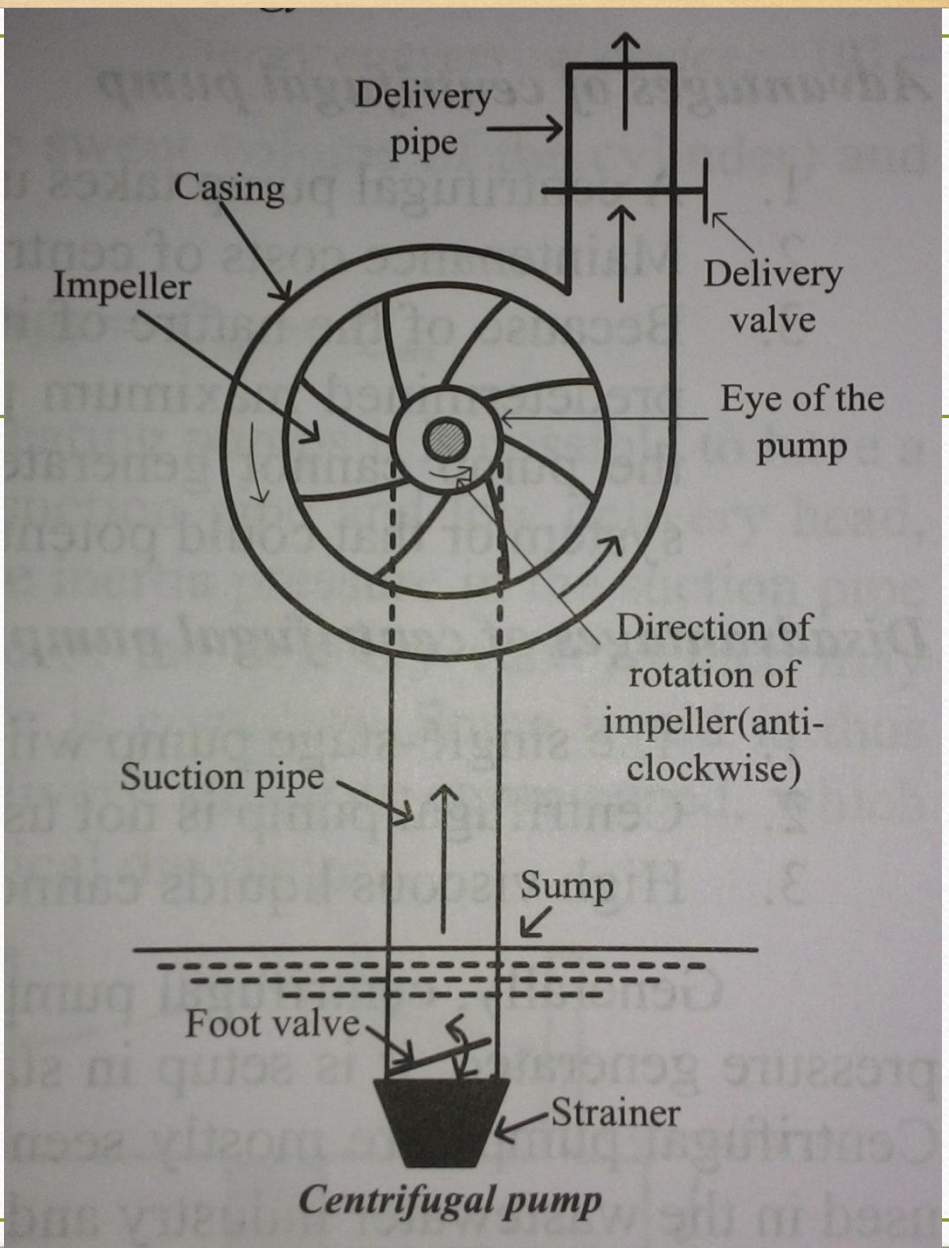
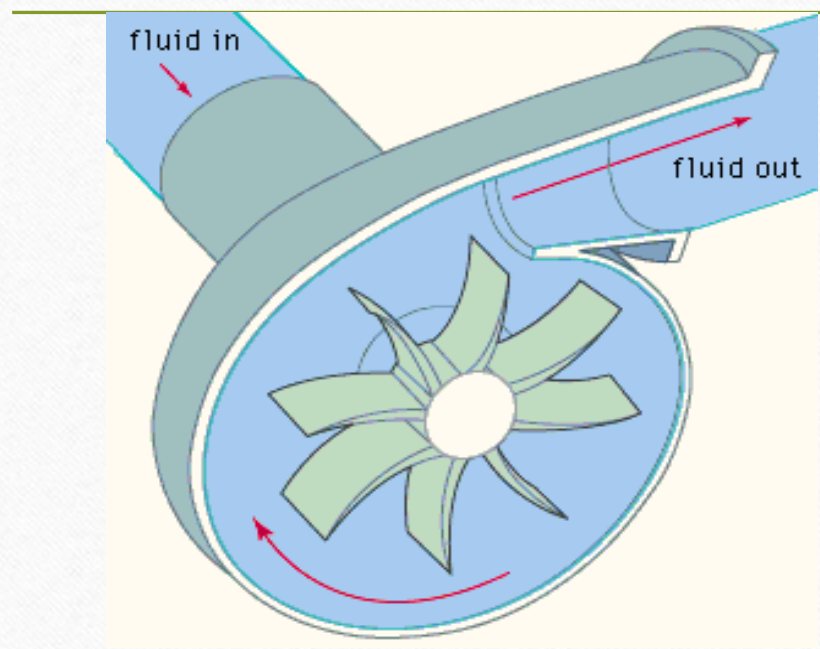

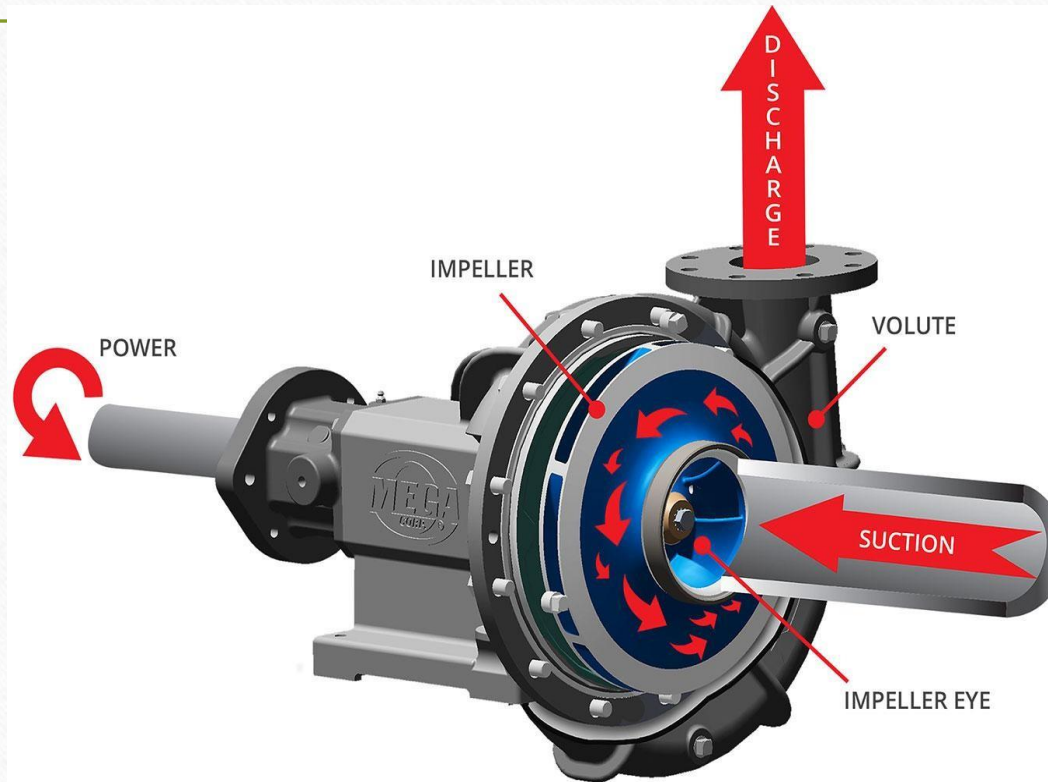

- A centrifugal pump is a rotodynamic pump that uses a rotating impeller to create flow by the addition of energy to a fluid



## Centrifugal Pump

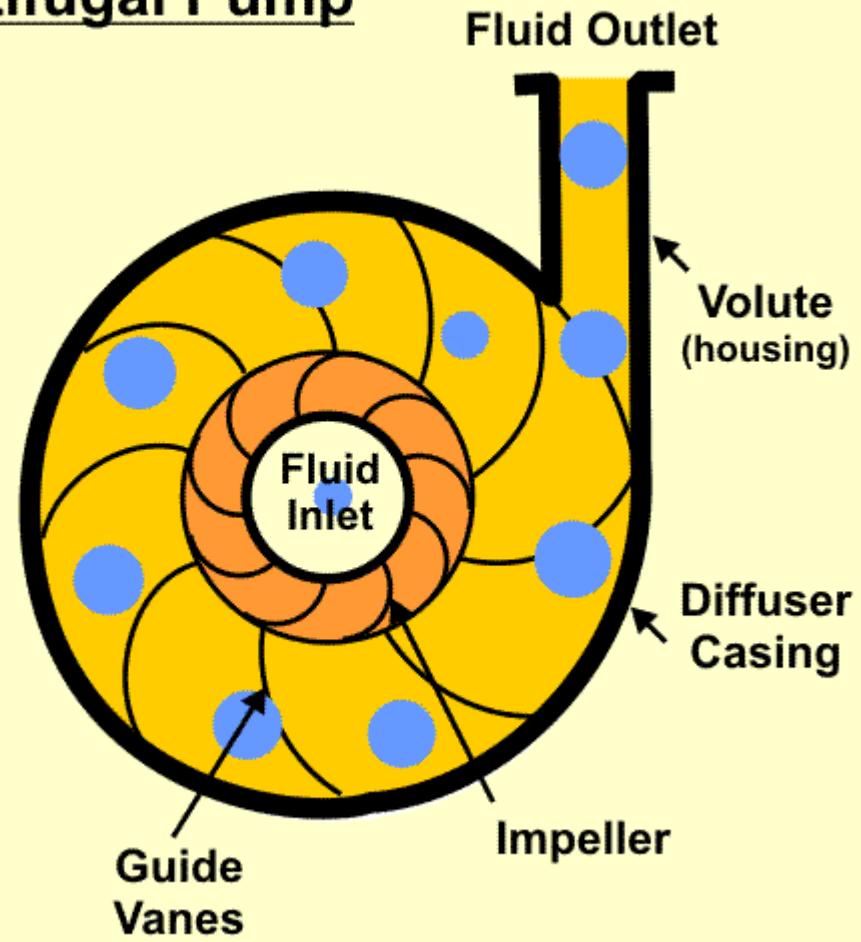

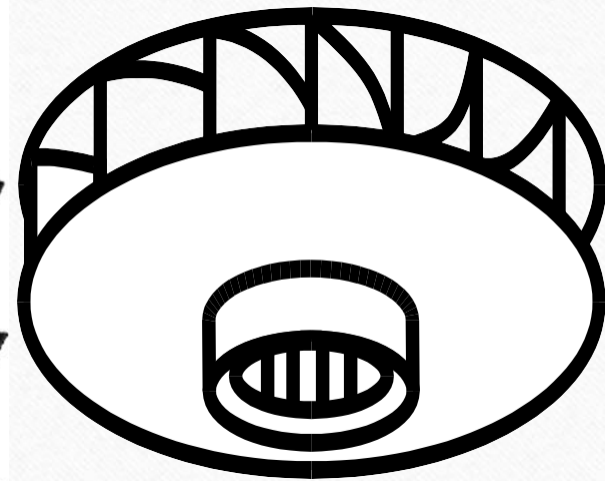
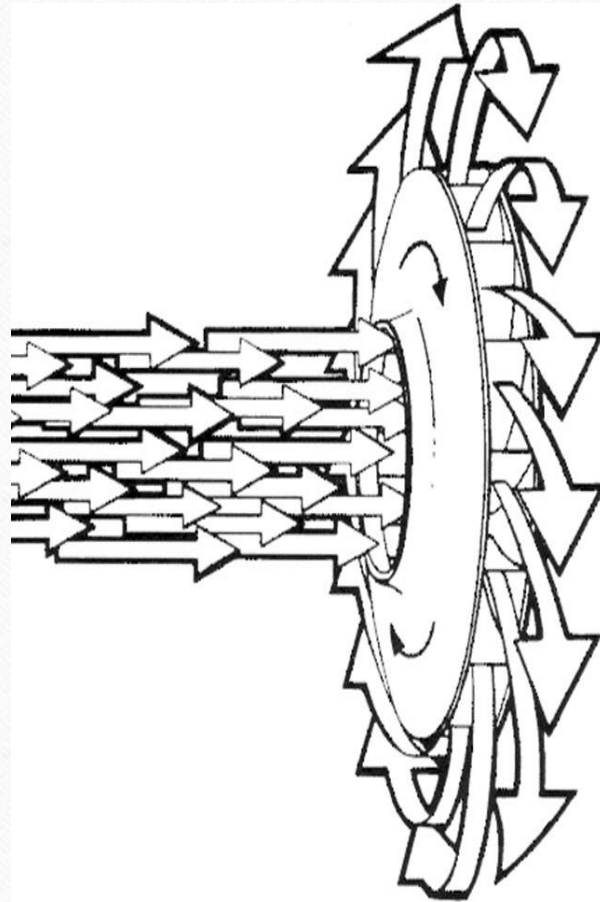
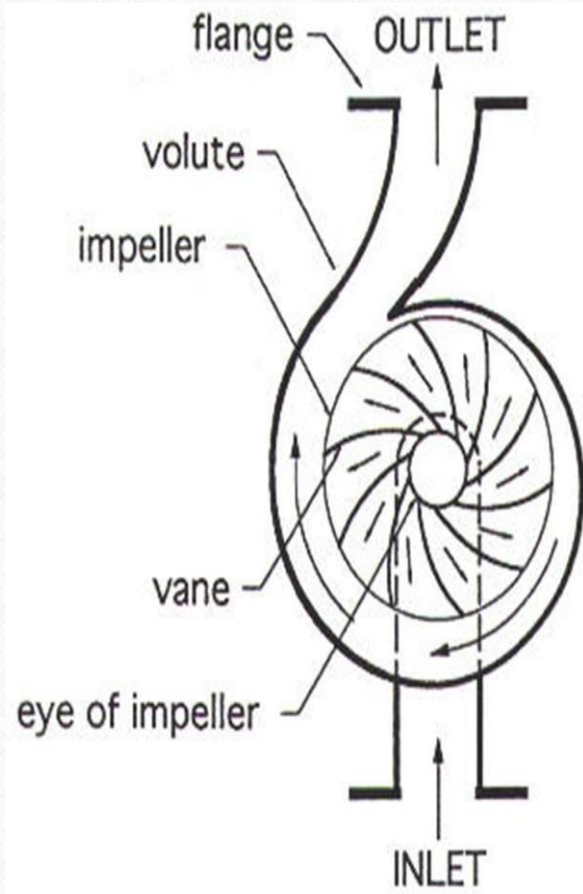



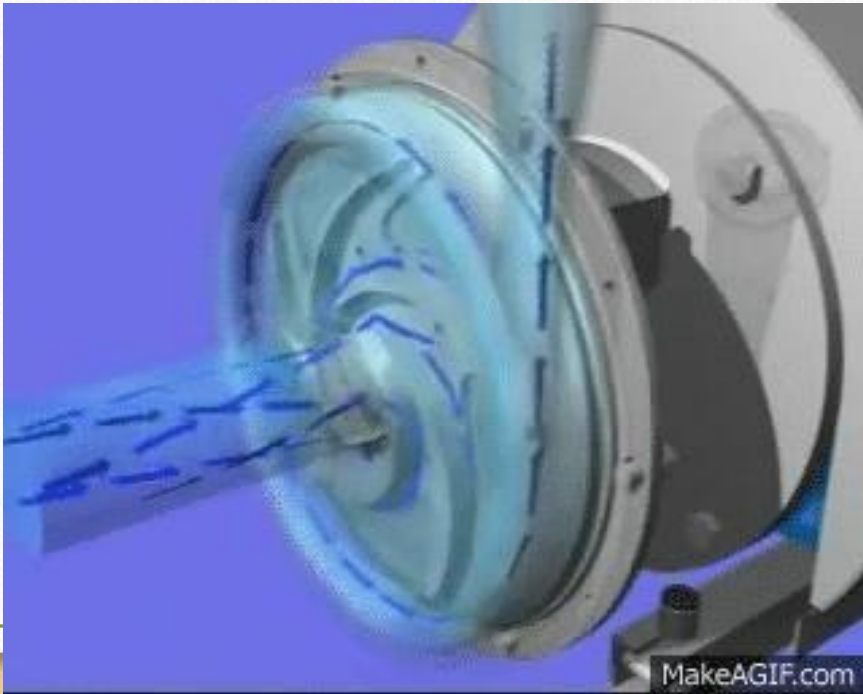

# TYPES OF IMPELLER



**ENCLOSED  
IMPELLER**



**SEMI-OPEN  
IMPELLER**



**OPEN  
IMPELLER**



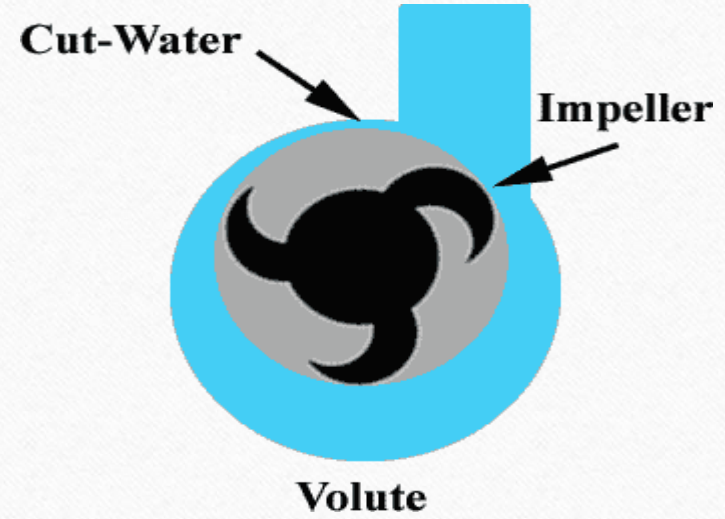

PUM CASIN  
P G

## Parts of a centrifugal pump

- 1) Impeller: Rotating solid disc with curved blades. Impeller is mounted on a shaft connected to the shaft of an electric motor. As the impeller rotates, fluid is drawn into the impeller inlet (eye of pump) is accelerated as it is forced radially outwards
- 2) Casing: Air tight passage around the impeller
- 3) Suction pipe and delivery pipe: Pipe whose one end is connected to the inlet of pump and other end dipped in a sump is known as suction pipe. Pipe whose one end is connected to the outlet of the pump and the other end delivers the working fluid at a required height is known as delivery pipe.



# Working

- Working fluid enters the pump at the centre of a rotating impeller.
- ~~Impeller impart centrifugal force on the liquid entrapped in the impeller~~  
and throws the liquid towards the outer periphery of the impeller
- Outward movement of liquid in the impeller creates a partial vacuum near the eye of the impeller. Consequently, liquid from the sump is sucked in towards the impeller eye and enters through the inlet tip of impeller vanes. Thus, there is a continuous flow of liquid from the sump to the casing
- The liquid leaving the impeller vanes is at a higher pressure and velocity
- The velocity head is converted to pressure head in the casing

# RECIPROCATING PUMP

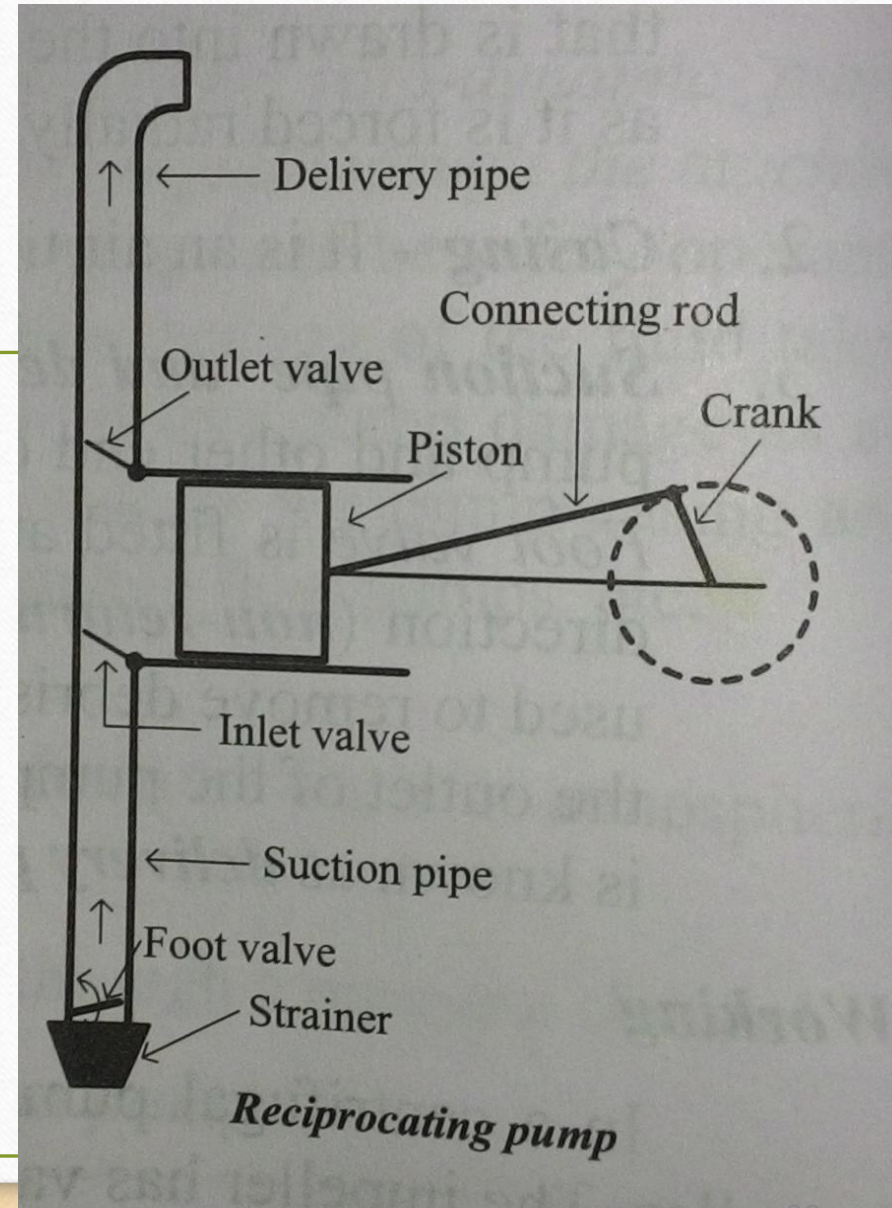
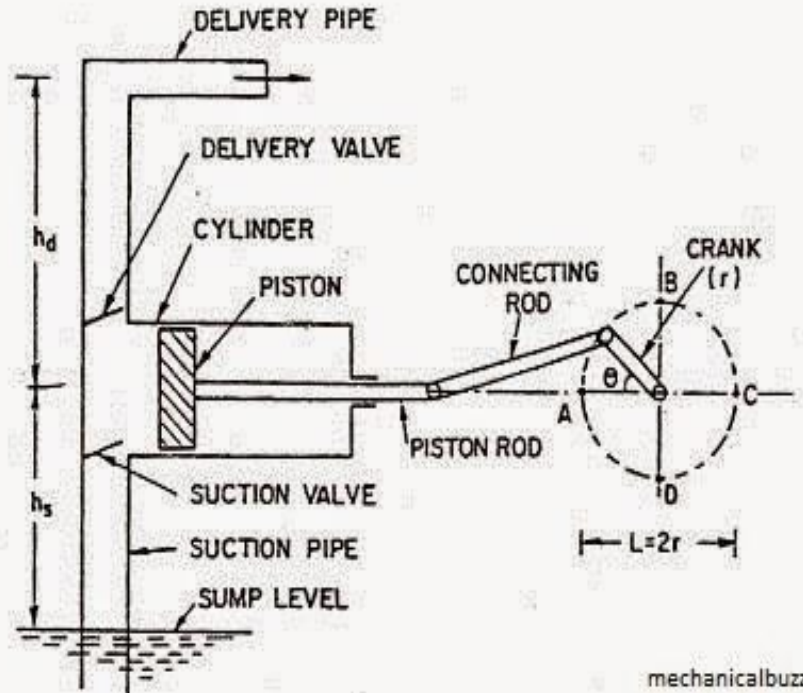



- Reciprocating pump is a positive displacement pump. It creates the lift and pressure by displacing the liquid using a moving mechanical element called plunger(piston) inside a cylinder

<https://www.youtube.com/watch?v=bJluUxA7aaY>

## ➤ Air Compressors :

- Air compressors account for significant amount of electricity used in Indian industries.
- Air compressors are used in a variety of industries to supply process requirements, to operate pneumatic tools and equipment, and to meet instrumentation needs.
- Only 10-30% of energy reaches the point of end-use, and balance 70-90% of energy of the power of the prime mover being converted to unusable heat energy and to a lesser extent lost in form of friction, misuse and noise.

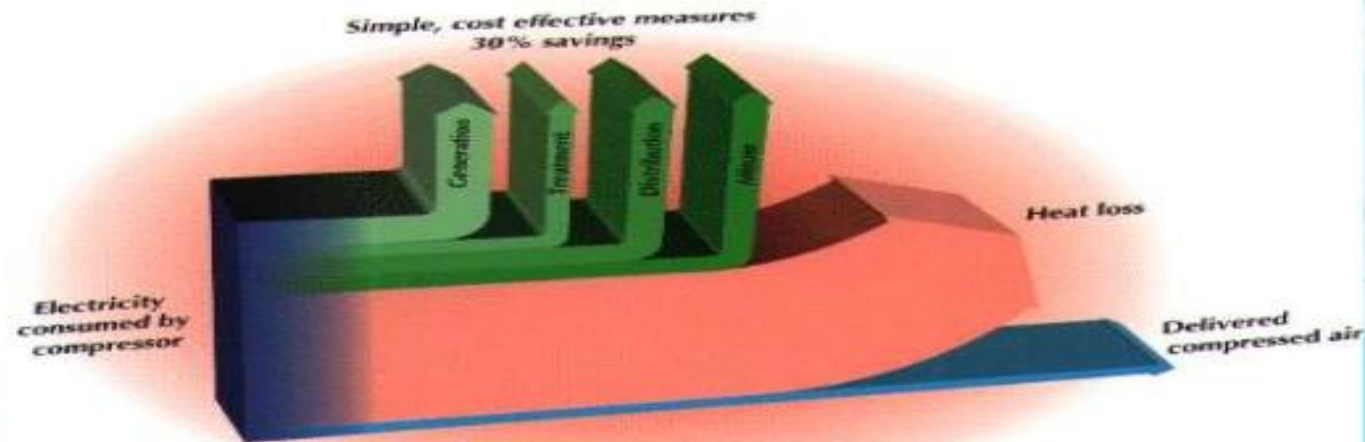



## Dynamic Compressors

- In this type of compressor the air is not trapped within the specified boundaries, but it flows at a steady rate continuously.

### Centrifugal Compressor :

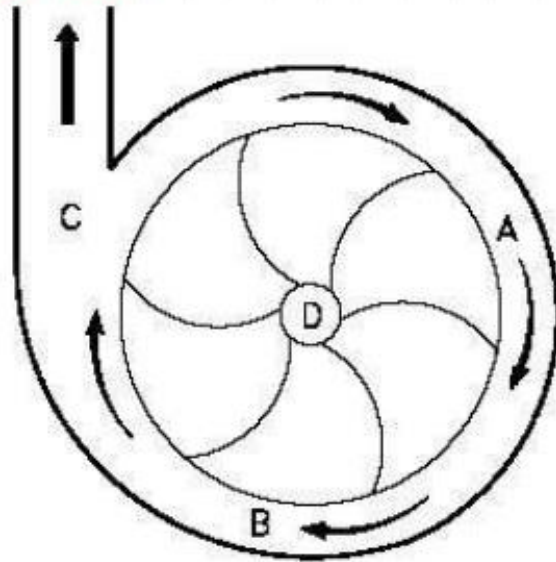

## Reciprocating Compressors

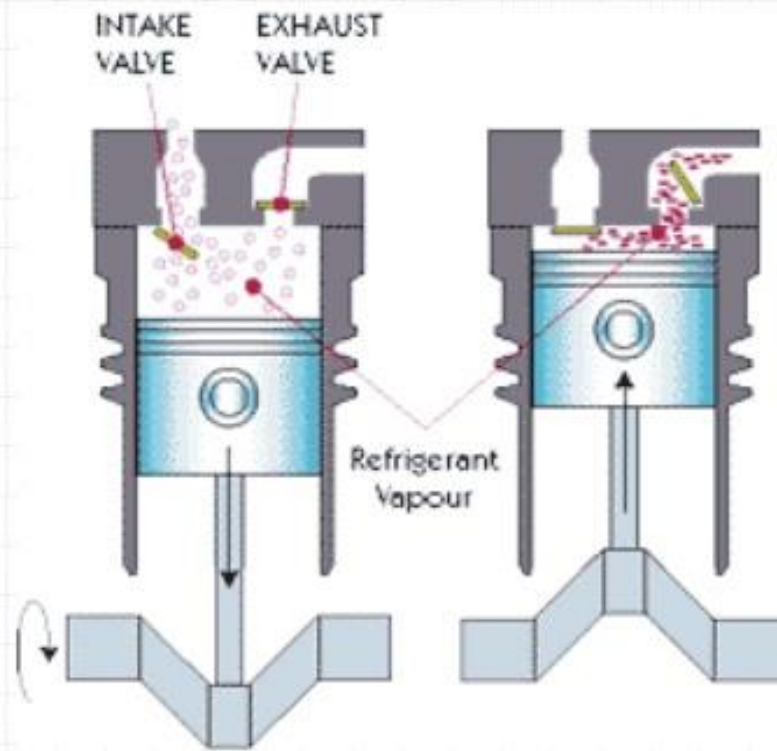



# Classification of Air Compressors

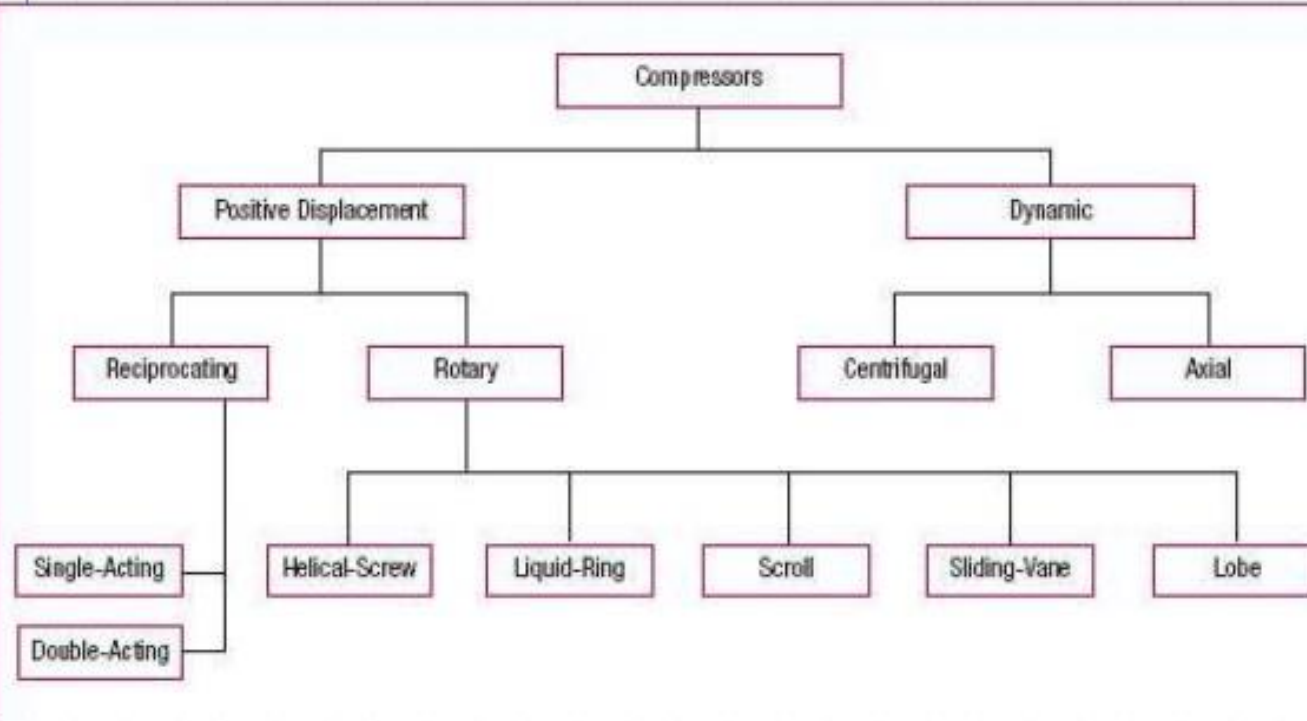

---

IMPULS  
E  
TURBIN  
E

HYDRAULIC  
TURBINES

REACTI  
ON  
TURBIN  
E



# HYDRAULIC TURBINES

<https://www.youtube.com/watch?v=XzopmHnXqwM>

[https://www.youtube.com/watch?v=qbyL--6q7\\_4](https://www.youtube.com/watch?v=qbyL--6q7_4)

- Turbines convert hydraulic energy or hydro-potential into mechanical energy.
- Mechanical energy developed by turbines is used to run electric generators coupled to the shaft of turbines
- Hydro electric power is the most cheapest source of power generation
- Modern hydraulic turbines have been developed by L.A. Pelton (Impulse), G. Coriolis and J.B. Francis (Reaction) and V Kaplan (Propeller)

## Classification of turbines

Turbines can be classified on the basis of:

---

### **Head and quantity of water available**

- **a) High head turbine**: Head is more than 250m, low discharge, eg. Pelton turbine
- **b) Medium head turbine**: 60m to 250m, medium discharge types, eg. Francis turbine
- **c) Low head turbine**: Head will be below 60m, high discharge, eg. Kaplan turbine



### **Direction of flow of water in the runner**

- **a) Tangential flow**: Water strikes tangentially, eg. Pelton turbine
- **b) Radial flow**: Water enters and leaves radially, eg. Francis turbine
- **c) Mixed flow** : Water enters radially and leaves axially, eg. Modern Francis turbine
- **d) Axial flow**: Water flows parallel to the axis of the turbine shaft, eg. Kaplan turbine

### **Action of water on moving blades**

- **a) Impulse turbine**: Water possess only kinetic energy at the inlet of the turbine, eg. Pelton turbine
- **b) Reaction turbine**: Water possess both kinetic energy and pressure energy at the inlet, eg. Francis and Kaplan turbine

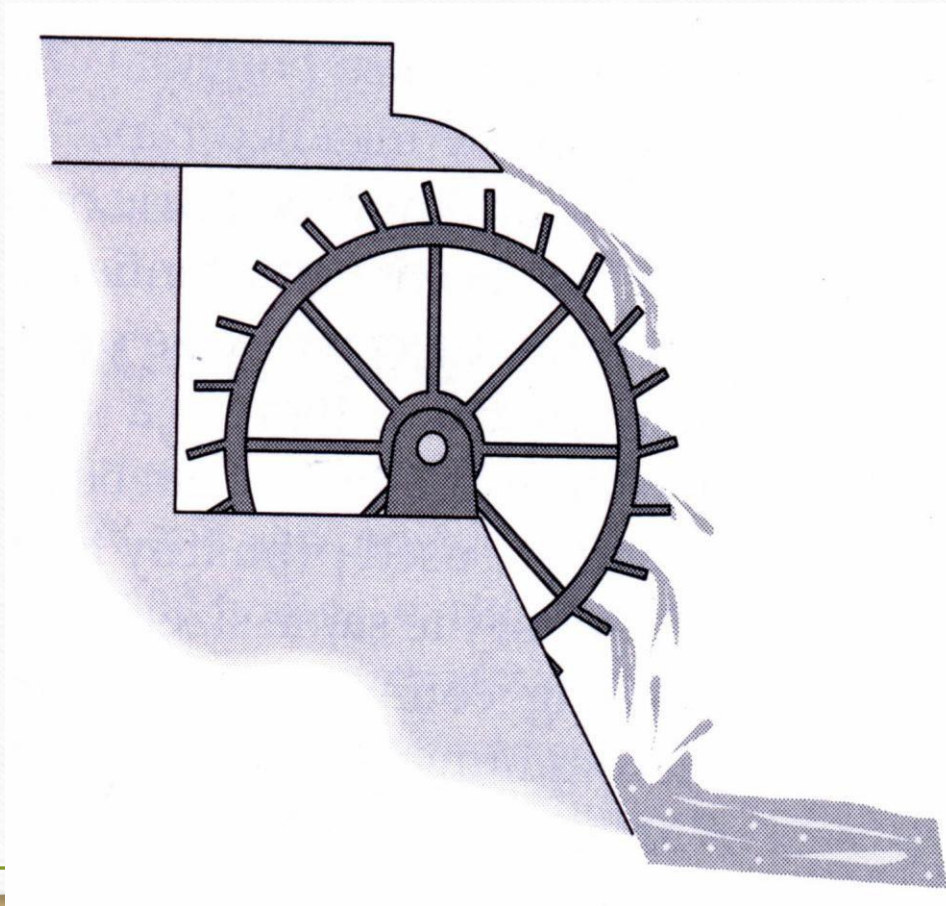

- Humans first learned to harness the kinetic energy in water by using **waterwheels**.
- A waterwheel is a revolving wheel fitted with blades, buckets, or vanes.
- Waterwheels convert the kinetic energy of flowing water to **mechanical energy**



# IMPULSE TURBINE

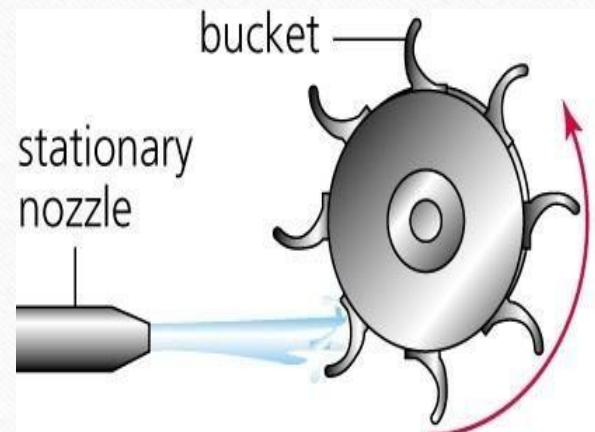
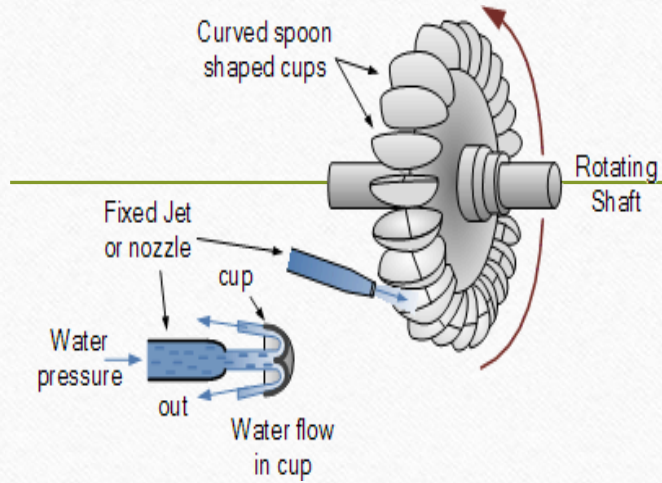

Impulse Turbine

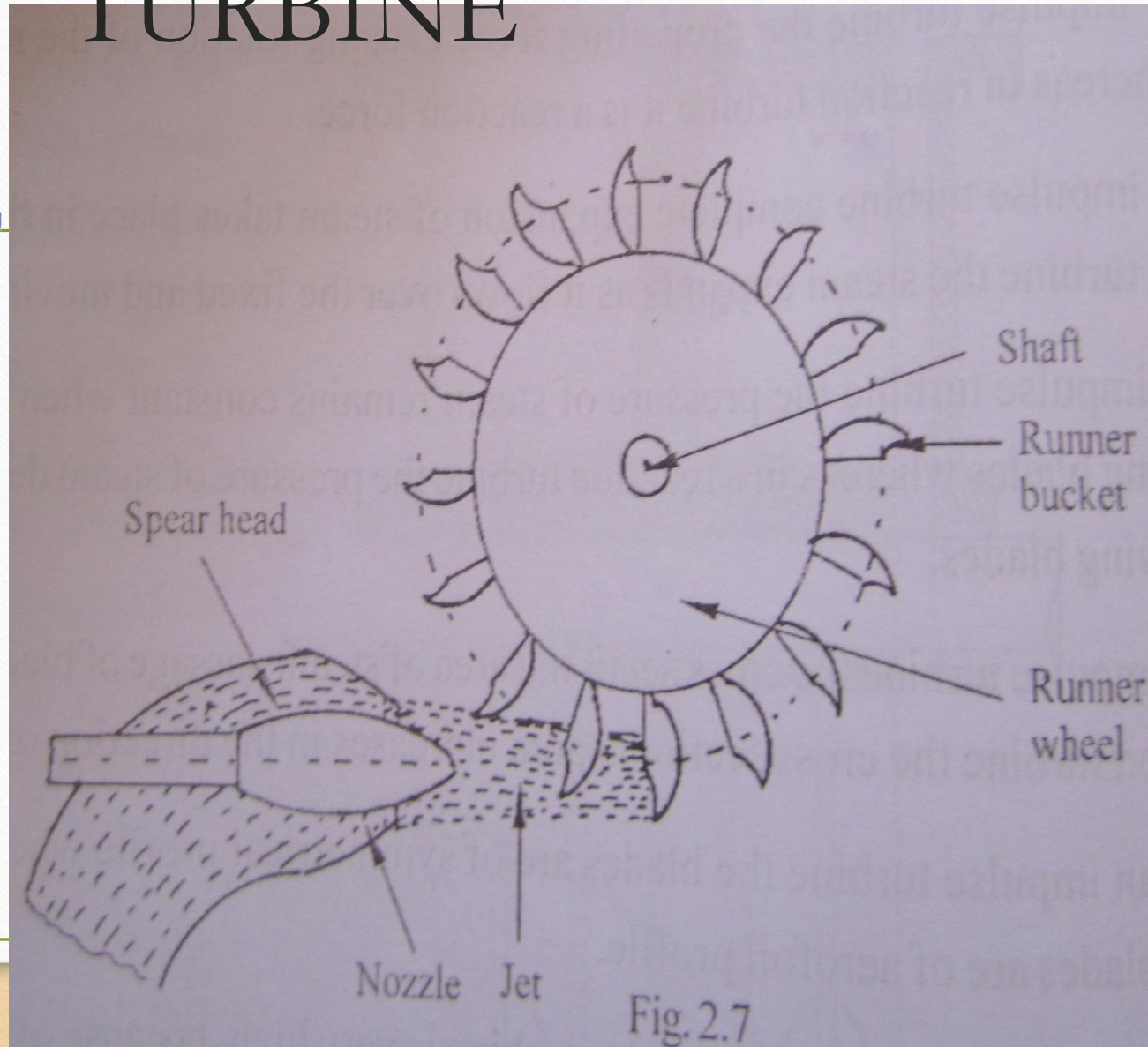



- **Pelton Wheel**

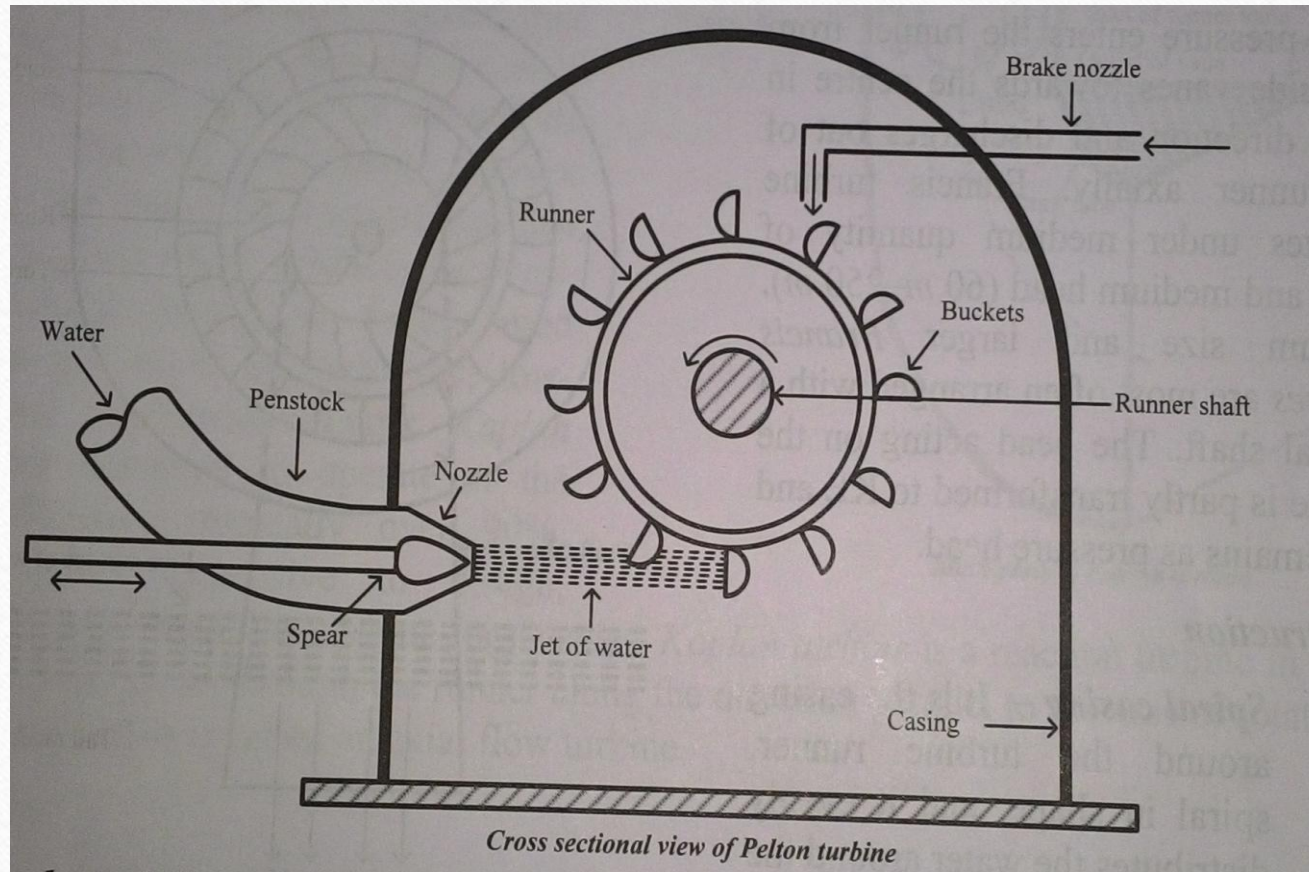



# Main Parts of a Pelton Turbine

- Nozzle and flow regulating arrangement
- Runner and buckets: Runner is a circular disc on the periphery of which a number of buckets are fixed
- Casing: Prevent the splashing of water
- Breaking jet: Used to stop the runner

## Working

- Nozzle directs the water against buckets mounted around the runner
- When the water jet strikes the bucket, the water exerts pressure on the bucket and hence the runner revolves.
- The runner shaft is connected with the generator, thus the electricity is produced

FRANCIS  
TURBINE

**REACTION  
TURBINES**

KAPLAN  
TURBINE



# FRANCIS

# TURBINE

<https://www.youtube.com/watch?v=3BCiFeykRzo>





- Water enters the runner from the guide vanes towards the centre in radial direction and discharges out of the runner axially

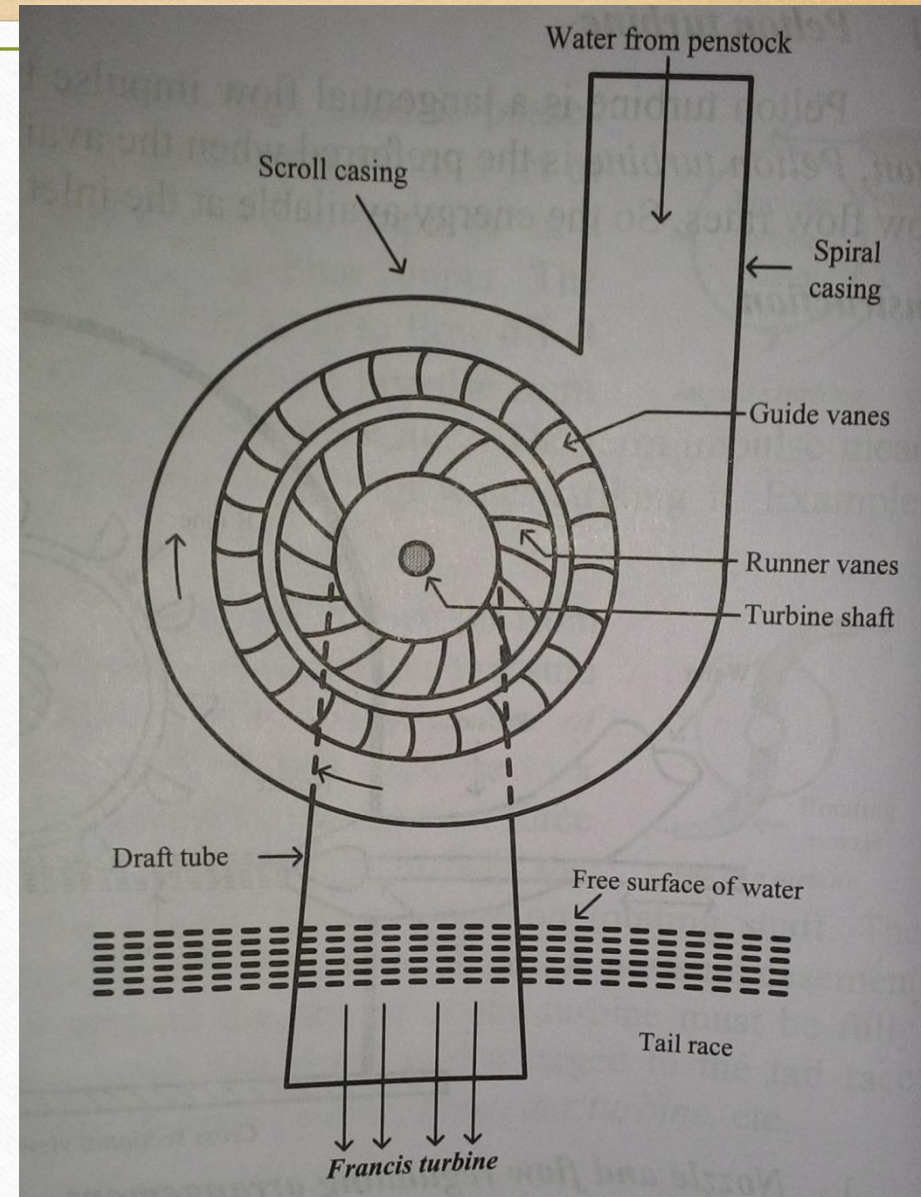





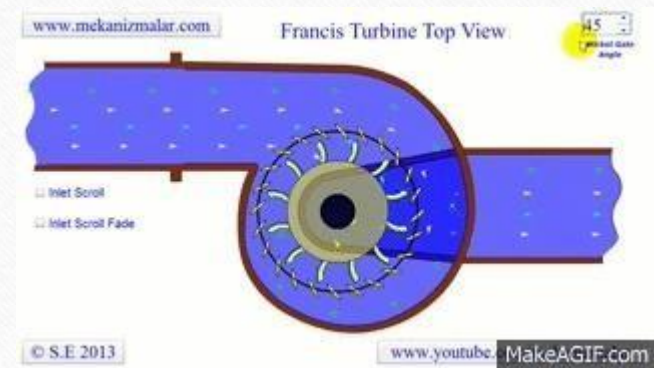
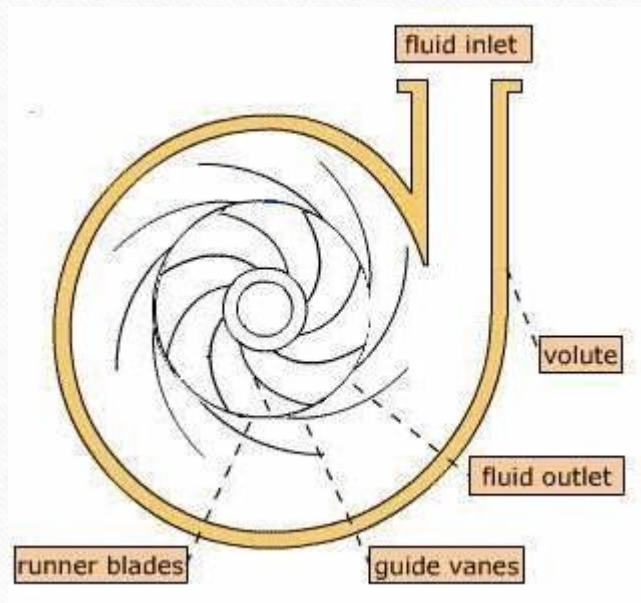



# WATER TURBINE

CAVITATION

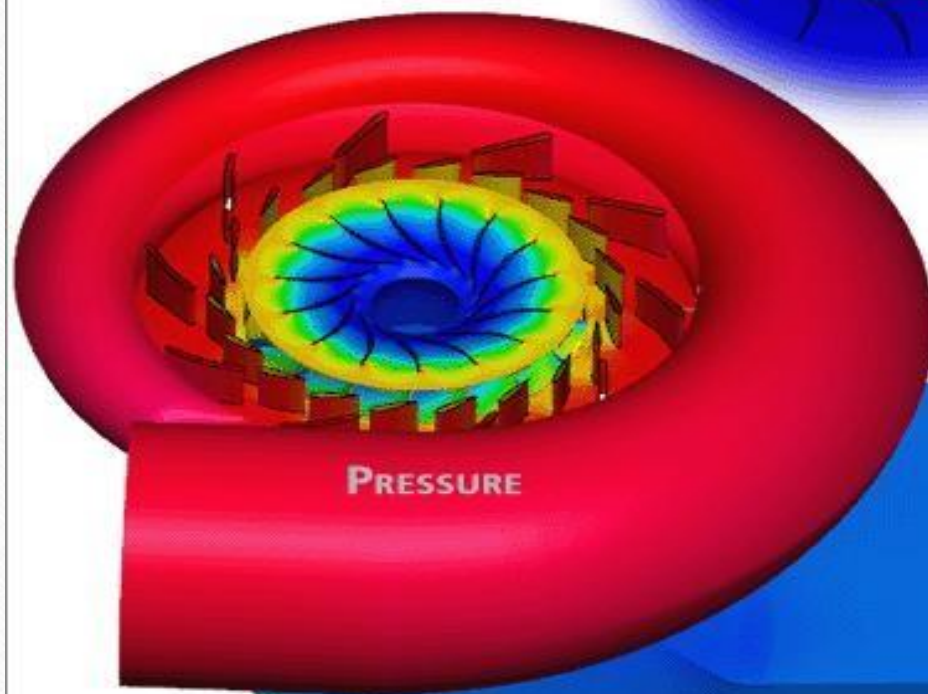

PRESSURE

## Main parts of Francis Turbine

- 
- Spiral casing: Maintain a uniform velocity around the guide vanes
  - Guide vanes: Around the circumference of the runner. It acts like a nozzle to increase the velocity of water. It also regulates the amount of water inlet to the turbine
  - Runner and runner vanes: Runner vanes have aerofoil like structure. Pressure difference on the blades cause the rotation
  - Draft tube: Water flows from runner outlet to tail race through draft tube



# KAPLAN TURBINE

<https://www.youtube.com/watch?v=0p03UTgpnDU>

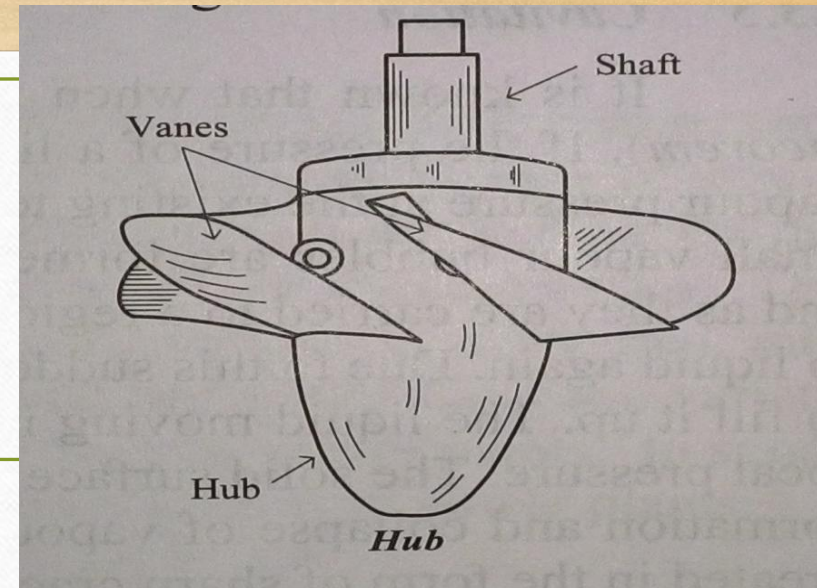
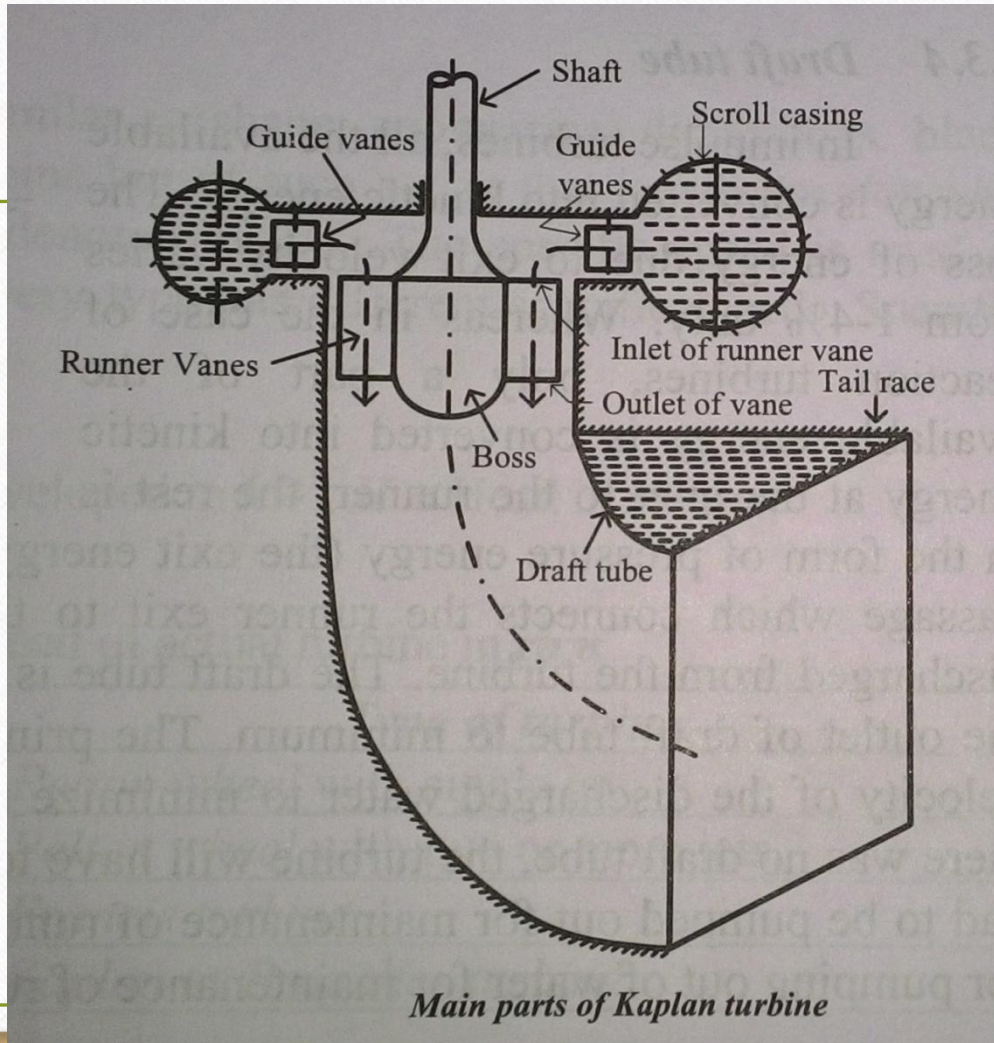



## Main parts of a Kaplan Turbine

---

- Scroll casing
- Guide vanes: Used to turn the water through  $90^\circ$
- Hub and vanes: Vanes are fixed to hub. Vanes are adjustable. Vanes are adjusted according to the flow rate. Vanes are aerofoil shaped profile
- Draft tube





# Steam Turbines

<https://www.youtube.com/watch?v=SPg7hOxFtI>



- Steam turbine is a prime mover in which pressure energy of steam is transformed into mechanical energy of rotation of turbine shaft



---

**IMPULSE  
TURBINES**

**STEAM TURBINES**

**REACTION  
TURBINES**

# IMPULSE TURBINE

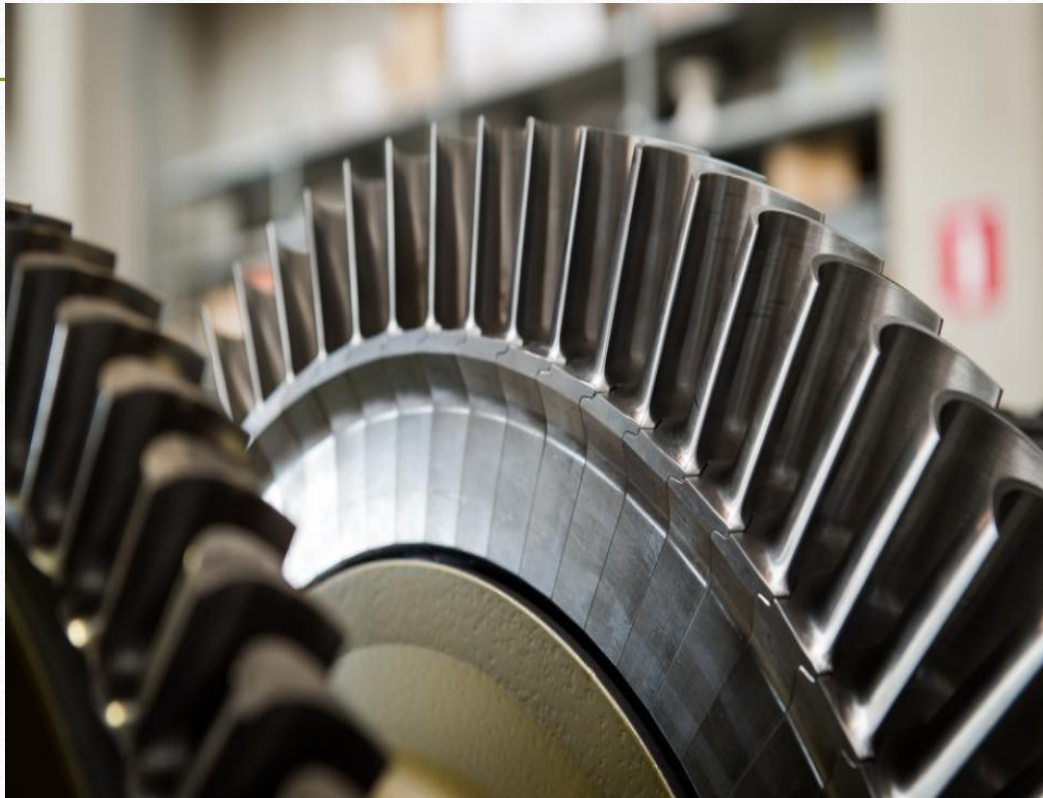



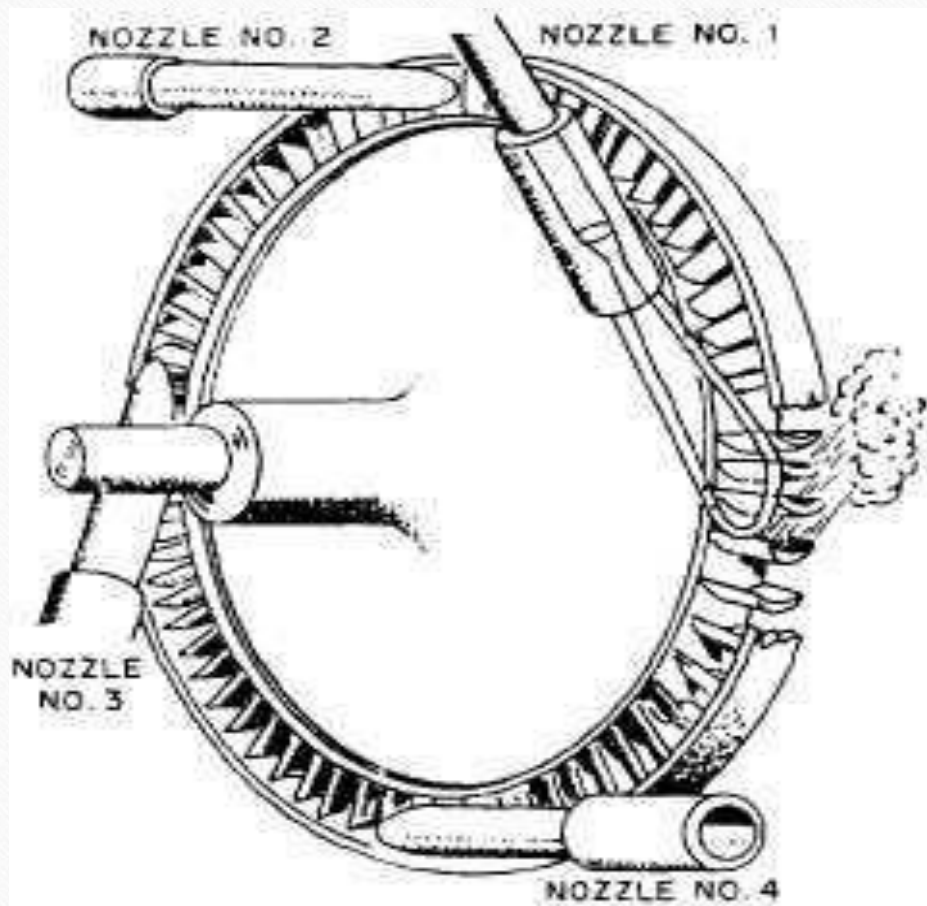

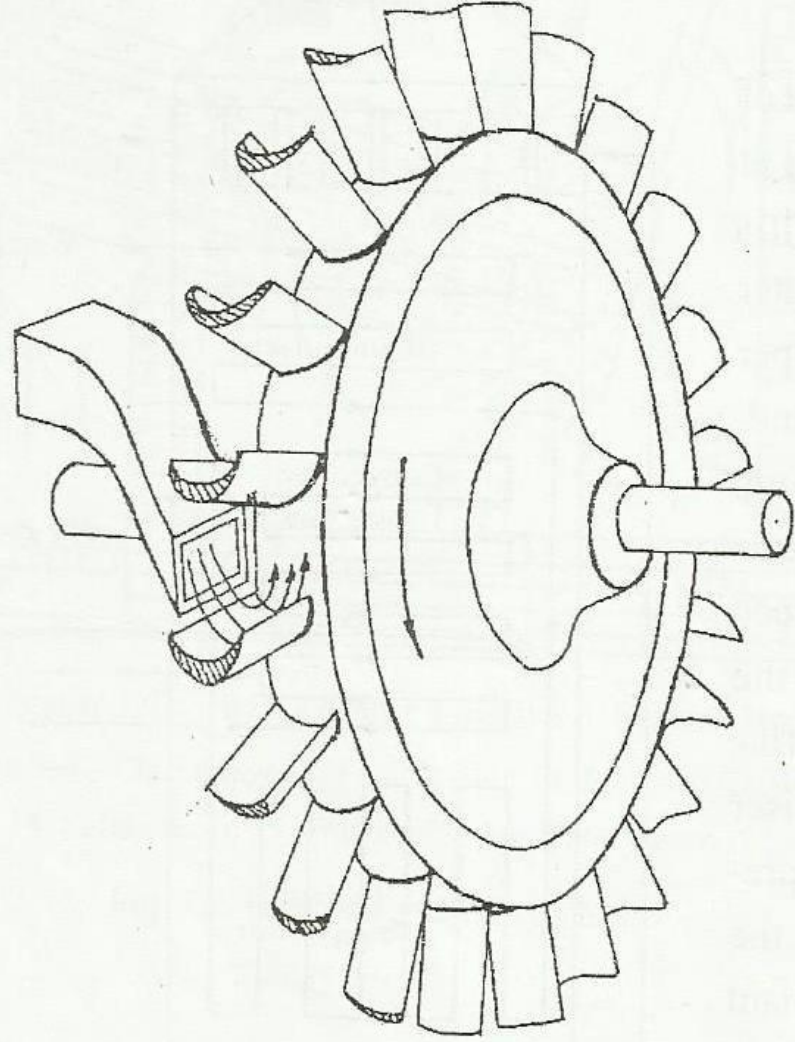



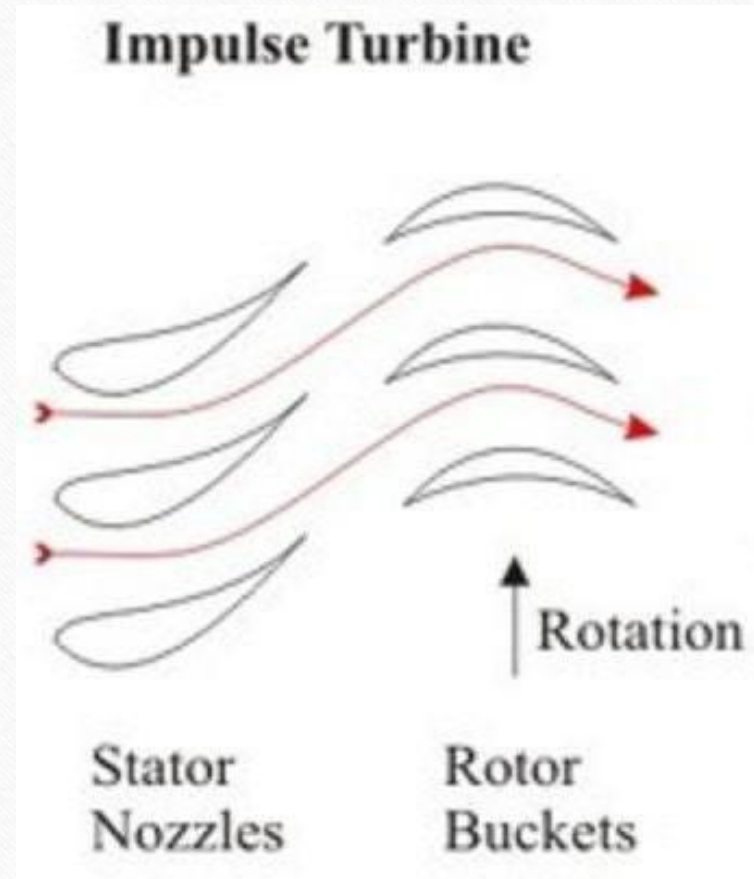
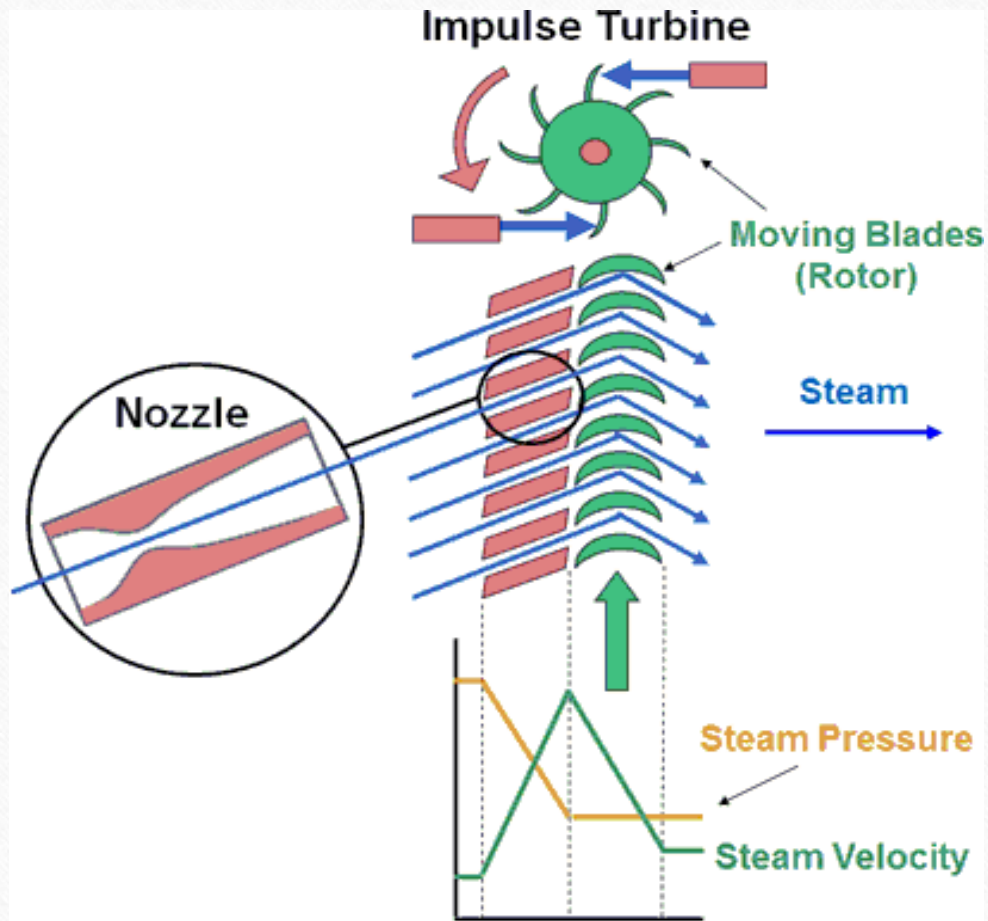

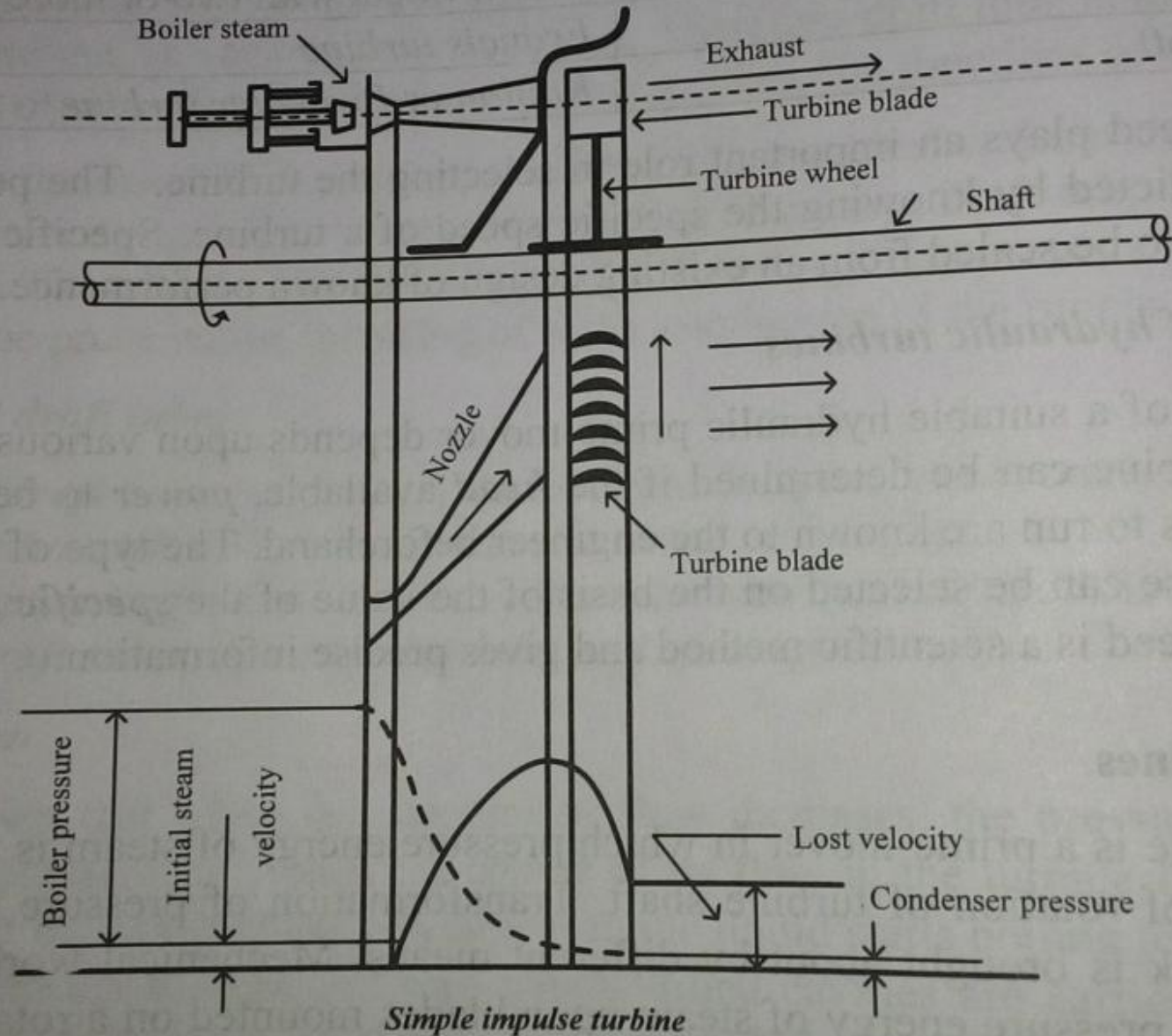

Simple impulse turbine



## Components

- Nozzle, Shaft, Disc with Curved Blades Fixed on it Periphery, Casing
- 

### **NOZZLE**

- Pressure energy decreases
- Kinetic energy increases

### **MOVING BLADES**

- Pressure remains constant
  - Velocity decreases



# REACTION TURBINE









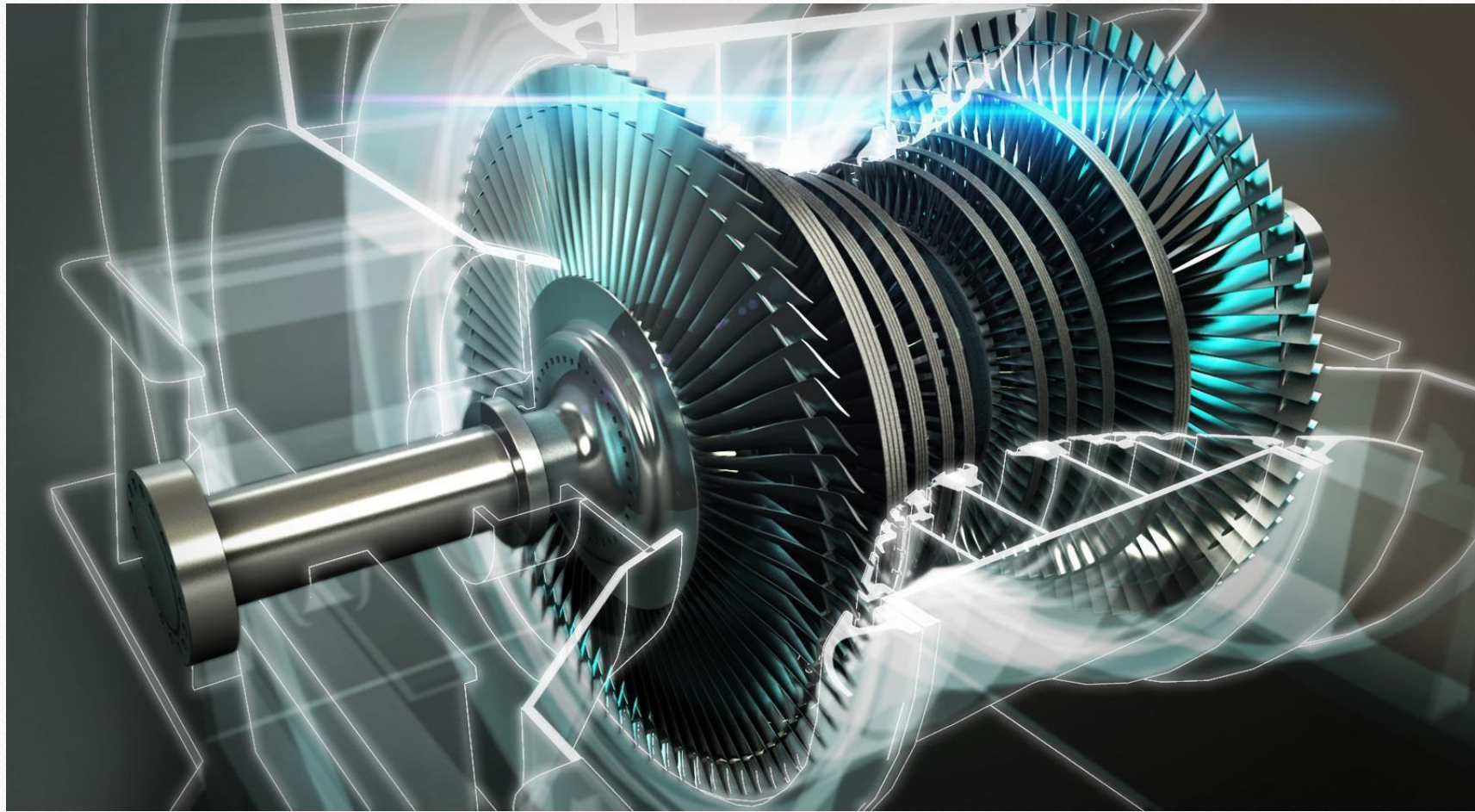



# Reaction Turbine

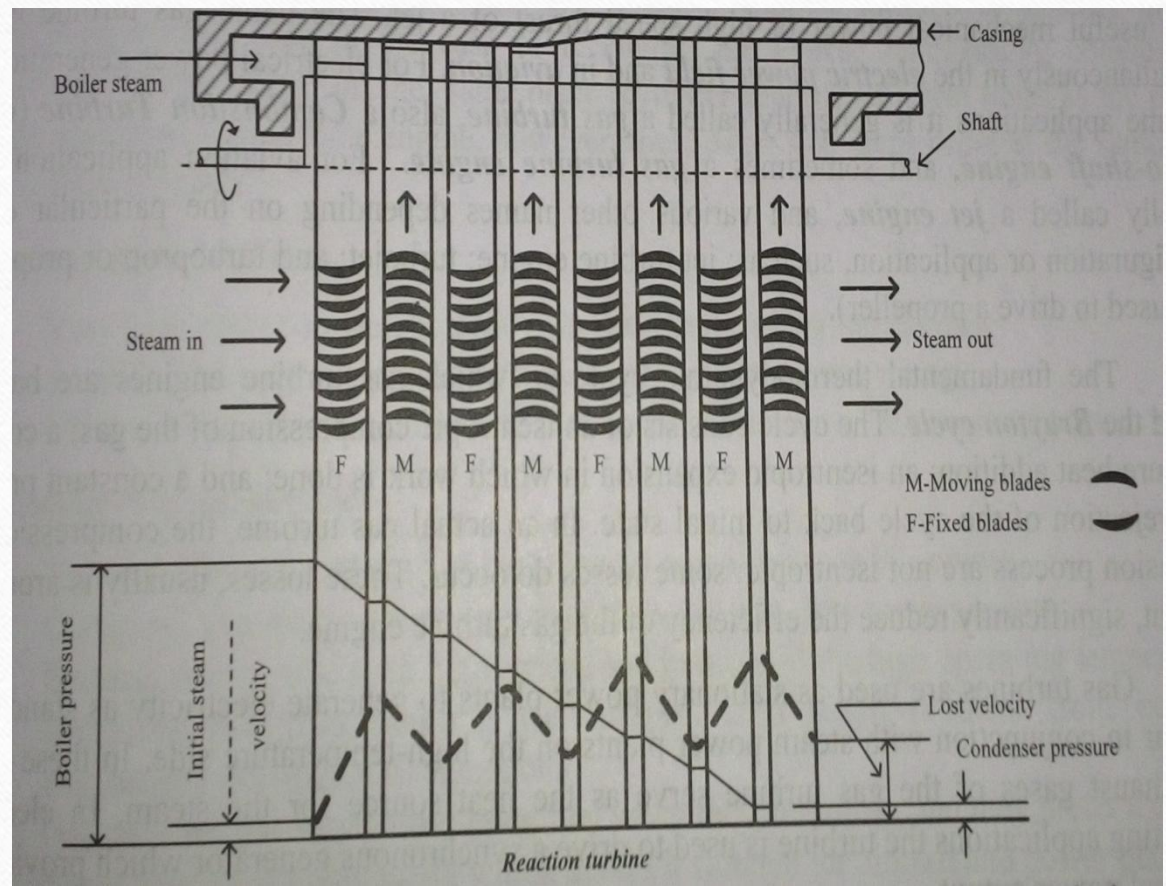
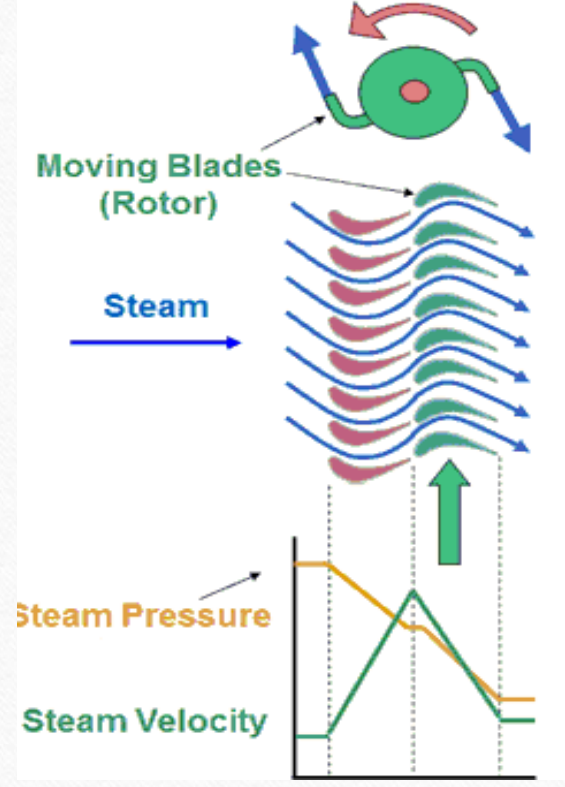

### Three Stage Pressure Compounded Steam Turbine

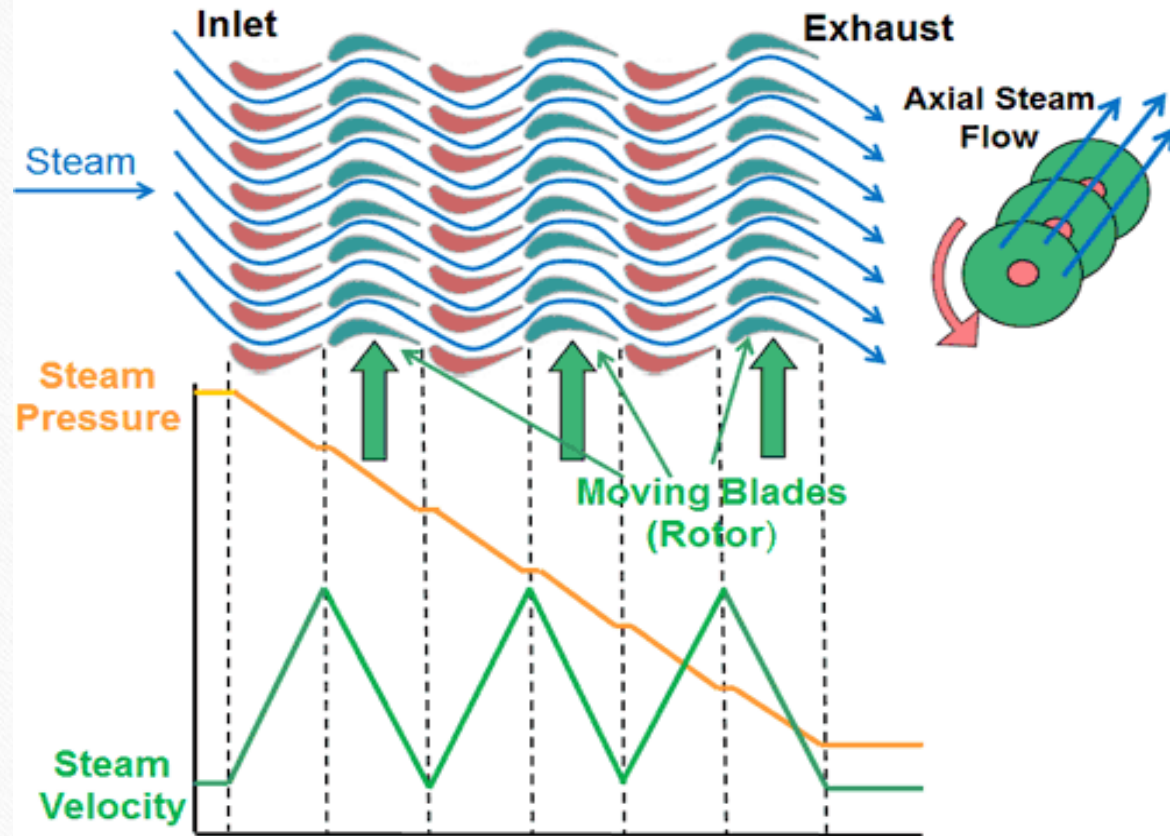



- Steam expands while flowing through fixed and moving blades. Therefore the cross sectional area increases in the direction of flow
- Blades are aerofoil profile

### **Fixed blades**

- Acts like a nozzle
- Velocity increases and pressure reduces

### **Moving blades**

- Velocity decreases and pressure also decreases
- Pressure drop in moving blades provide the reactive force

# Comparison of Impulse and Reaction steam turbine

## **IMPULSE TURBINE**

- Expansion taken place in the nozzle
- Blades are symmetrical profile
- Size is small for same output
- Speed is very high
- Cross sectional area of steam passage is same

## **REACTION TURBINE**

- Expansion of steam taken place over fixed and moving blades
- Blades are aerofoil profile
- Size is large
- Speed is not high
- Cross sectional area increases in the direction of flow



# GAS TURBINE S

---

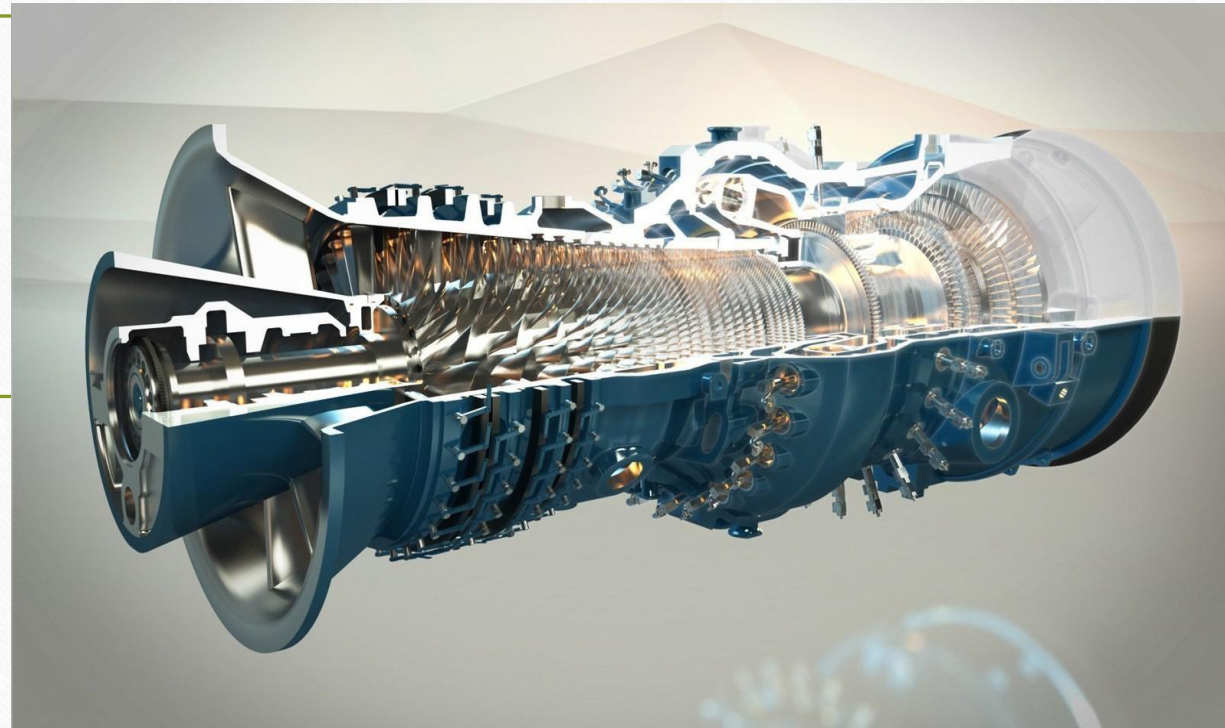

- Device that converts the thermal energy of a working fluid(hot gas) into useful mechanical power

**CLOSED  
CYCLE GAS  
TURBINE**

**GAS  
TURBINE**

**OPEN CYCLE  
GAS TURBINE**



# Open Cycle Gas Turbine

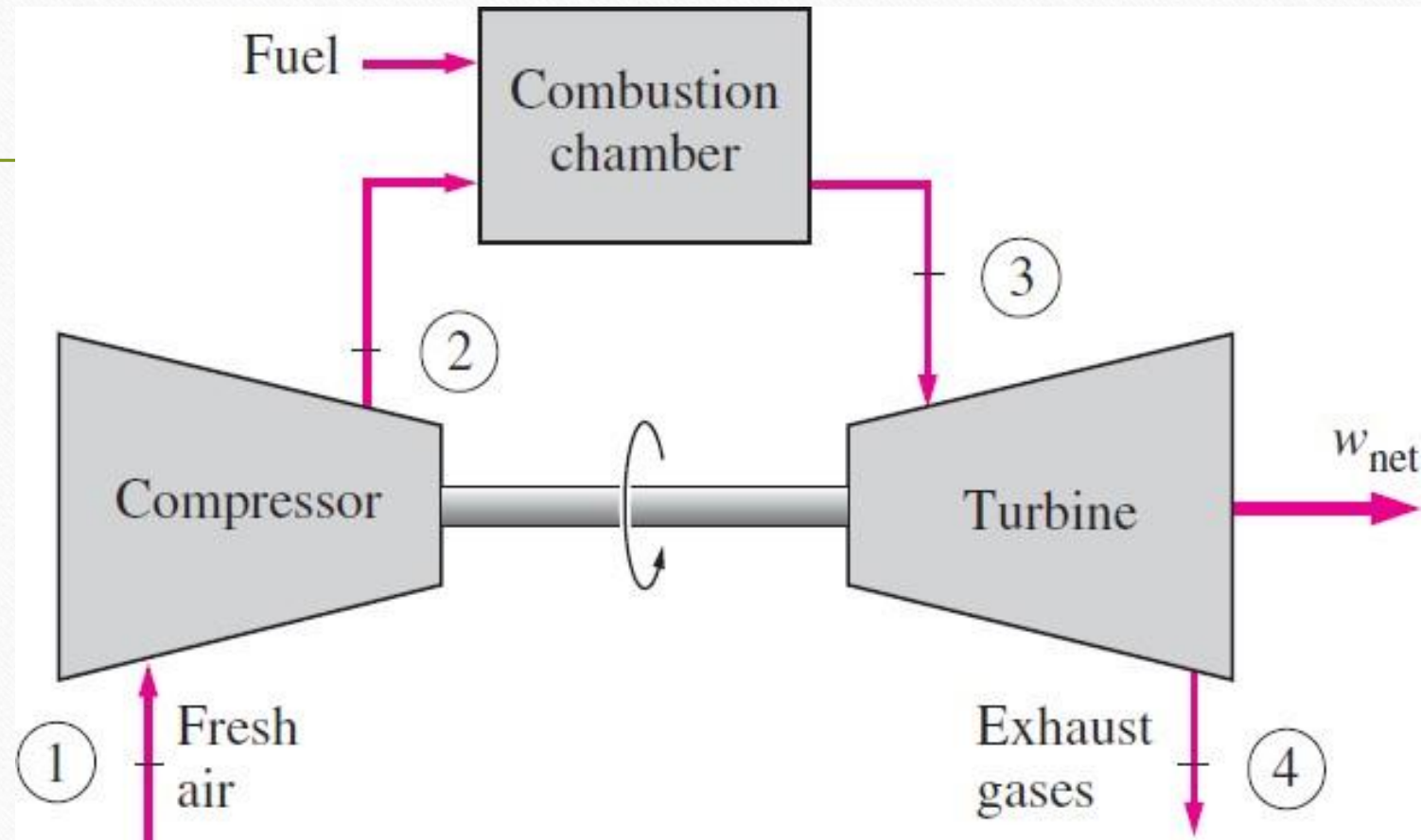

- Compressor takes in ambient air and raises its pressure
- High pressure gas then enters into the combustion chamber. After combustion, the product of combustion is expanded in the turbine to develop work
- Part of the turbine work is used to drive the compressor
- The expanded product is discharged to the atmosphere



# Closed Cycle Gas Turbine

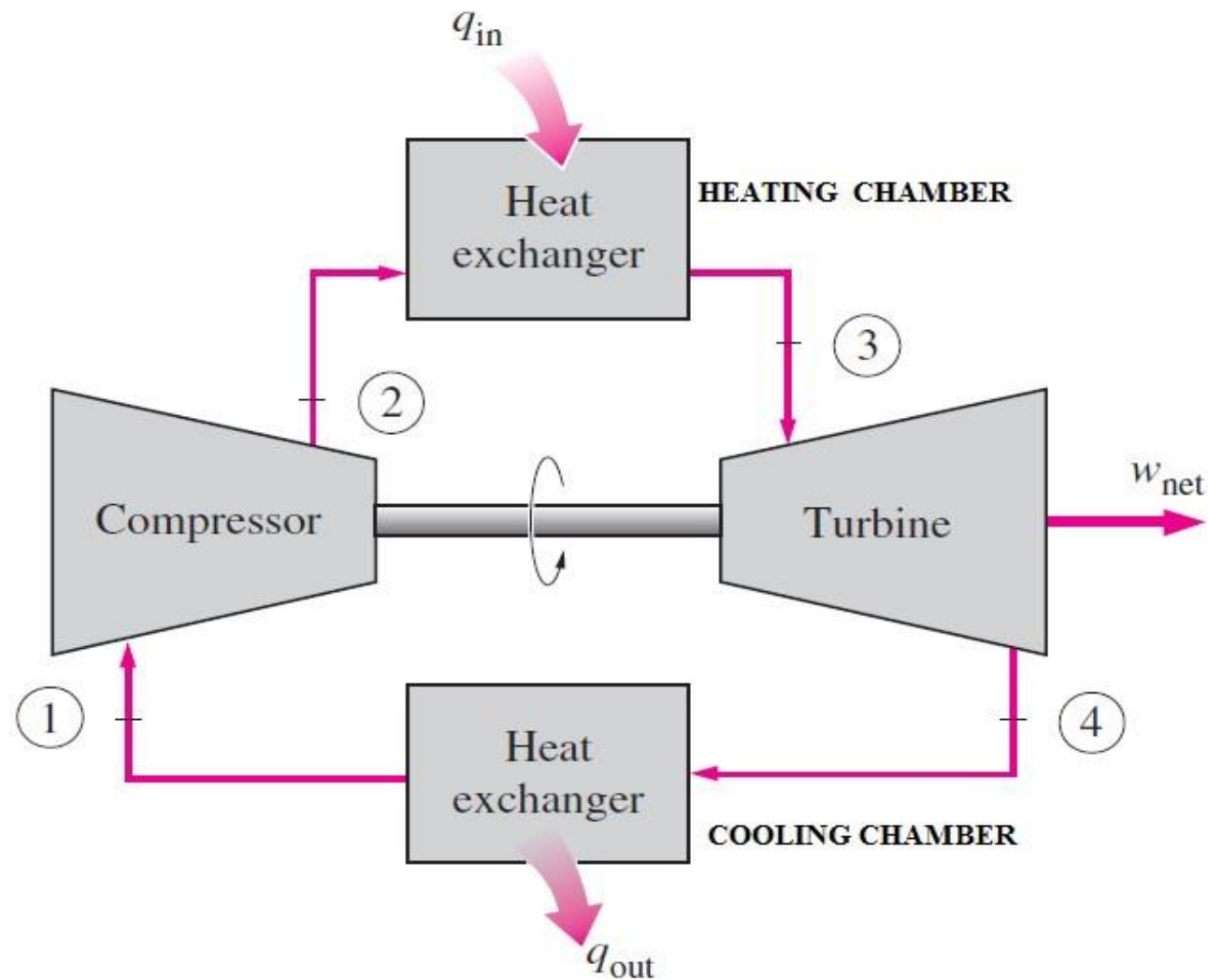

- Same working fluid is continuously circulated
- Heat of product of combustion is transferred to the compressed working medium using a heating chamber
- Heat is removed from the expanded working medium using a cooling chamber



## Comparison of closed cycle and open cycle gas turbine

### Closed Cycle

---

- High thermal efficiency
- More complex system
- Coolant is needed
- Working fluid is circulated continuously
- Any fluid with better thermodynamic properties can be used
- Strong enough to resist high pressures
- Turbine vane do not wear away much

## Open Cycle

- Less thermal efficiency
- 
- Less complex system
  - Coolant is not needed
  - Working fluid is repeated continuously
  - Only air can be used as working fluid
  - Contaminated air increases the wear rate of turbine vane